

About the Author

Education:

Electrical Engineering, Pennsylvania State University

Work Experience:

Hewlett Packard: Thirty four years filling various positions
(retired in 2004)

Spokane Washington 1981 to 2004

- **RF Products Division in Spokane WA** -1981 to 2004 -
Regional Sales Support, Application Engineering, World
Wide Sales Management, Systems Development and
Product Management

About the Author (continued)

Valley Forge PA - from 1969 until 1981

- Engineering Technical Support, Technical Customer Training and Field Sales Engineer

American Electronics Laboratories From 1962 to 1969

- working in and managing a Metrology (Calibration Standards) Laboratory responsible for maintaining test instruments and their calibration accuracy traceability to the National Bureau of Standards (**NBS**) now the called National Institute of Standards and Technology (**NIST**).

Jerrold Electronics from 1959 to 1961

- Electronics Technician in the R&D laboratory

About the Author (continued)

ARRL Appointments:

- ARRL VE (Volunteer Examiner)
- ARRL Technical Specialist for Spokane area
- ARRL Technical Coordinator for Eastern Washington (EWA)
- ARRL Registered Instructor
- ARRL Certified EMCOMM instructor

Amateur radio Extra Class License Class

© Jack Tiley - July 2, 2016



*Based on July 1, 2016 to June 30, 2020 Question Pool
Jack Tiley AD7FO, Spokane Valley, WA*

US Amateur Radio Bands

US AMATEUR POWER LIMITS

FCC 97.313 An amateur station must use the minimum transmitter power necessary to carry out the desired communications. (b) No station may transmit with a transmitter power exceeding 1.5 kW PEP.

Effective Date
March 5, 2012

Published by:
ARRL The national association for
AMATEUR RADIO[®]
www.arrl.org
225 Main Street, Newington, CT USA 06111-1494



KEY

Note:
CW operation is permitted throughout all amateur bands.

MCW is authorized above 50.1 MHz, except for 144.0-144.1 and 219-220 MHz.

Test transmissions are authorized above 51 MHz, except for 219-220 MHz

- = RTTY and data
- = phone and image
- = CW only
- = SSB phone
- = USB phone, CW, RTTY, and data
- = Fixed digital message forwarding systems only

- E = Amateur Extra
- A = Advanced
- G = General
- T = Technician
- N = Novice

See *ARRLWeb* at www.arrl.org for detailed band plans.

ARRL
We're At Your Service

ARRL Headquarters:
860-594-0200 (Fax 860-594-0259)
email: hq@arrl.org

Publication Orders:
www.arrl.org/shop
Toll-Free 1-888-277-5289 (860-594-0355)
email: orders@arrl.org

Membership/Circulation Desk:
www.arrl.org/membership
Toll-Free 1-888-277-5289 (860-594-0338)
email: membership@arrl.org

Getting Started in Amateur Radio:
Toll-Free 1-800-326-3942 (860-594-0355)
email: newham@arrl.org

Exams: 860-594-0300 email: vec@arrl.org

Copyright © ARRL 2012 rev. 4/12/2012

160 Meters (1.8 MHz)

Avoid interference to radiolocation operations from 1.900 to 2.000 MHz

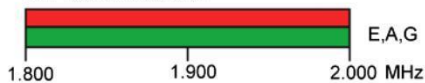

80 Meters (3.5 MHz)

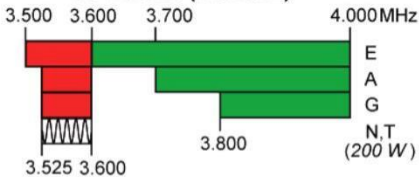

60 Meters (5.3 MHz)

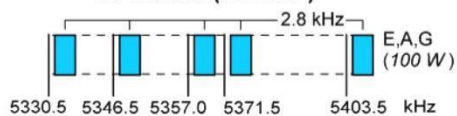

General, Advanced, and Amateur Extra licensees may operate on these five channels on a secondary basis with a maximum effective radiated output of 100 W PEP. Permitted operating modes include upper sideband voice (USB), CW, RTTY, PSK31 and other digital modes such as PACTOR III as defined by the FCC Report and Order of November 18, 2011. USB is limited to 2.8 kHz centered on 5332, 5348, 5358.5, 5373 and 5405 kHz. CW and digital emissions must be centered 1.5 kHz above the channel frequencies indicated above. Only one signal at a time is permitted on any channel.

40 Meters (7 MHz)

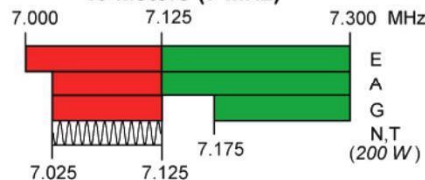

Phone and Image modes are permitted between 7.075 and 7.100 MHz for FCC licensed stations in ITU Regions 1 and 3 and by FCC licensed stations in ITU Region 2 West of 130 degrees West longitude or South of 20 degrees North latitude. See Sections 97.305(c) and 97.307(f)(11). Novice and Technician licensees outside ITU Region 2 may use CW only between 7.025 and 7.075 MHz and between 7.100 and 7.125 MHz. 7.200 to 7.300 MHz is not available outside ITU Region 2. See Section 97.301(e). These exemptions do not apply to stations in the continental US.

30 Meters (10.1 MHz)

Avoid interference to fixed services outside the US.



20 Meters (14 MHz)

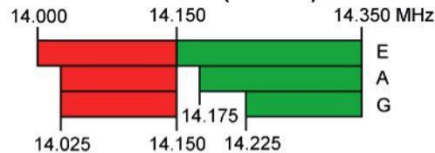

17 Meters (18 MHz)

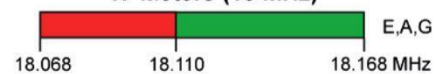

15 Meters (21 MHz)

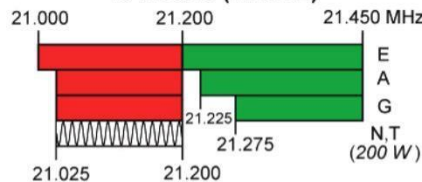

12 Meters (24 MHz)

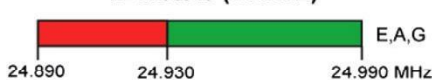

10 Meters (28 MHz)

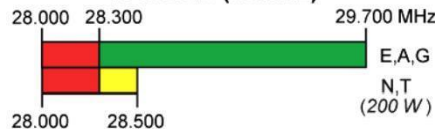

6 Meters (50 MHz)



2 Meters (144 MHz)



1.25 Meters (222 MHz)

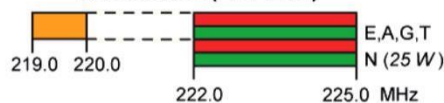

*Geographical and power restrictions may apply to all bands above 420 MHz. See *The ARRL Operating Manual* for information about your area.

70 cm (420 MHz)*



33 cm (902 MHz)*



23 cm (1240 MHz)*



All licensees except Novices are authorized all modes on the following frequencies:

2300-2310 MHz	10.0-10.5 GHz *	122.25-123.0 GHz
2390-2450 MHz	24.0-24.25 GHz	134-141 GHz
3300-3500 MHz	47.0-47.2 GHz	241-250 GHz
5650-5925 MHz	76.0-81.0 GHz	All above 275 GHz

* No pulse emissions

Electrical and Electronic Basics

Metric system Basics

Giga **XXXXXX** = 1,000,000,000 (one thousand million)

Mega **XXXXXX** = 1,000,000 (one million) times

Micro **XXXXXX** = 1/1,000,000 (one millionth)

Kilo **XXXXXX** = 1,000 (one Thousand)

Mili **XXXXXX** = 1/1,000 (one thousandth)

Nano **XXXXXX** = 1/1,000,000,000 (one thousandth of a Micro)

Pico **XXXXXX** = 1/1,000,000,000,000 (One millionth of a millionth)

Examples: Megamiles Millions of miles

Kilograms Thousands of grams

Microinches one millionth of an inch

Nanoinches One millionth of a Microinch

Voltage, Resistance and Current Flow:

Everything we use in our amateur station requires a power source that delivers a specific voltage and current. **Electro Motive Force** (*EMF*) commonly referred to as **Voltage** (**V**) is similar to the water pressure in a dam. The flow of current is measured in **amperes** and is commonly represented by the letter **I** and is similar to the flow of water in a pipe at the bottom of the dam. The amount current flowing in a circuit is limited by the circuit resistance **R** measured in ohms. This is similar to changing the diameter of the pipe coming out of the dam to decrease or increase the flow of water.

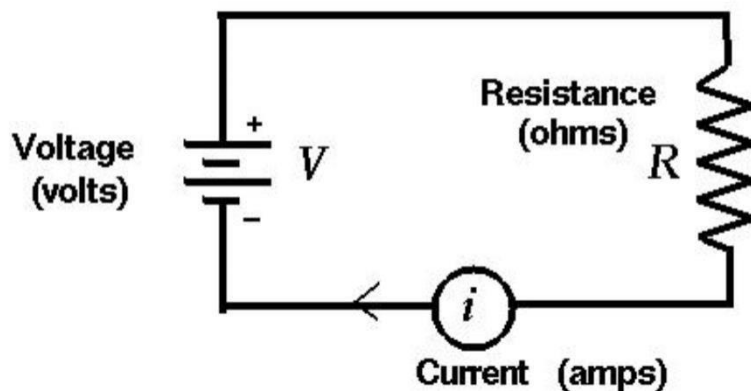

If we know the voltage and the resistance we can calculate the current that would be flowing in amperes using the following expression:

Current I (amperes) is equal to the Electro Motive Force E (volts) divided by Resistance R (ohms).

$$I \text{ (amperes)} = E \text{ (voltage)} \div R \text{ (resistance)}$$

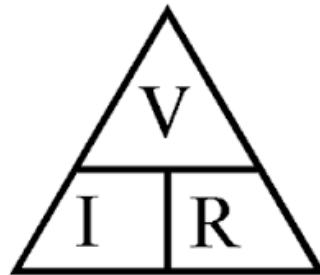

For example:

With a 12 volt battery across a 6 ohm resistor the current flowing would be 2 amperes.

$$\text{Current} = 12 \text{ volts} \div 6 \text{ Ohms} \text{ or } \text{Current} = 2 \text{ amperes}$$

With a 4 ohm resistor across a 24 v Battery the current flowing would be 6 amperes.

$$\text{Current} = 24 \text{ volts} \div 4 \text{ Ohms} \text{ or } \text{Current} = 6 \text{ amperes}$$

Powering our devices

There are two types of power available to power our devices, Direct Current (**DC**) and Alternating Current (**AC**).

1. Direct Current:

Direct Current (DC) is a voltage source that has two terminals one positive and one negative. Typically DC power is available from batteries, accessory jacks in vehicles, and plug in power supplies. Commonly used batteries for amateur radio applications include the following:

- **Alkaline and Zinc Carbon Batteries** -They produce 1.5 Volts - available in AAA, AA, C and D cells. **These batteries are not rechargeable.**
- **Lithium Batteries**- Lithium Batteries are long life batteries that produce 1.5 or 3 volts. A typical example would be AAA, AA and coin cells. **These batteries are not rechargeable.**

Nickel Cadmium (NICAD) and Nickel Metal Hydride (NIMH) -These batteries produce 1.2 volts, and are available in AAA, AA, C, D cells, and custom shapes. **These batteries are rechargeable.**

Saturated Lead Acid Batteries that produce 12 volts. These contain a liquid electrolyte (sulphuric acid) and cannot be tipped over or laid on their side or upside down. **These batteries are rechargeable.**

Deep Cycle Marine Batteries These batteries are similar to Saturated Lead Acid Batteries but are designed to handle a deep discharge better than the standard automotive type. **These batteries are rechargeable**

Sealed Lead Acid batteries -Gel Cells and AGM (Absorbed Glass Mat) batteries are sealed and use a “gelled” electrolyte and they can be operated in any position. They have high current ratings ranging. **These batteries are rechargeable**

Alternating Current Alternating Current (**AC**) is a voltage that alternates between equal positive and negative values. This is what is available from the wall outlet at home. The common 120 volt outlet at home delivers a voltage that goes from a positive peak of + 170 volts to a negative peak of -170 volts 60 times per second or 60 Hertz (Hz) rate. AC voltage at the outlet is specified as the average (RMS) value of the voltage over one cycle which is 120 volts. AC has the advantage that it can be easily converted to a higher or lower voltage.

The 120 Volts we normally associate with the outlets in our home is the equivalent to a DC voltage that would provide the same heating effect (or work) of a 120 volt DC voltage (known as the RMS value of the AC voltage). The heating effect of AC is less than the peak value because the voltage is continuously changing over the time for each cycle.

The difference between the work done by Direct Current vs Alternating Current can be seen in the illustration below. Only when voltage is present will work be accomplished, which in the case of the sine wave which is less than 100% of the time. The light purple area is an alternating DC voltage with the same value as the peak voltages as the sine wave. Since voltage is present all the time work is done continuously. This means a sine wave with the same peak values as the alternating DC waveform will do less work such as powering a light bulb or hair dryer. The green area represents the effective RMS energy available from our AC waveform.

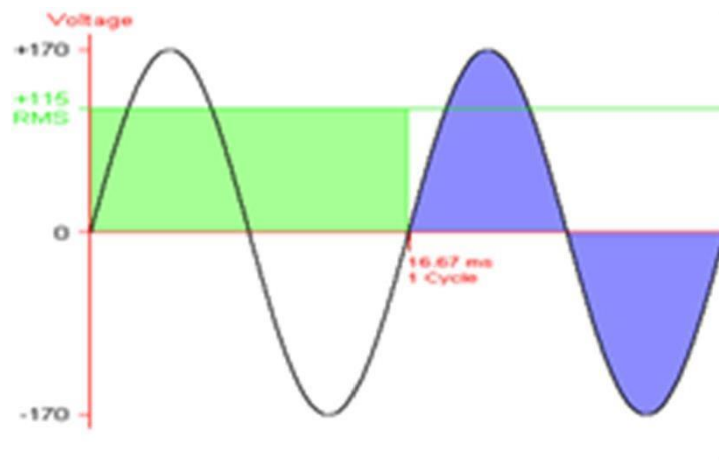

FREQUENCY:

Frequency is the number of times per second that an event occurs. Shown below is a single cycle of a sine wave, as it would be displayed on an oscilloscope. To determine its frequency you would divide the time in seconds for one cycle into 1.00.

If we start at the wave rising through 0 volts the next time it passes through 0 volts in the positive direction we can measure the period (or time) for one cycle of the waveform.

For example: If the time it takes for one cycle of a sine wave is .01 Seconds (10 milliseconds) the frequency would be 100 times a second or 100 Hz.

Frequency = $1 \div .01$ or Frequency = $1 \div .01$ or Frequency = 100

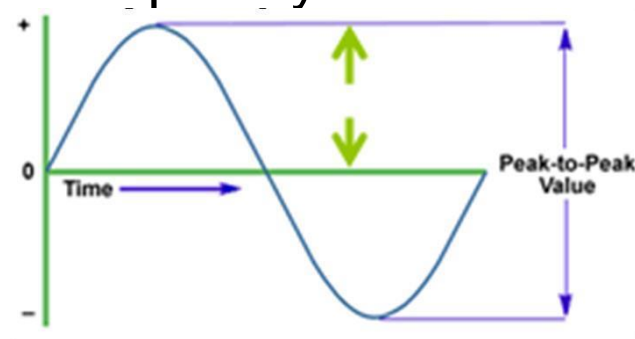

Examples:

What is the frequency of a sine wave with a 20 ms (millisecond) period for one cycle?

$$F = 1 \div \text{time} \text{ or } F = 1 \div .020 \text{ or } F = 50 \text{ Hz}$$

What is the frequency of a sine wave with a 1 μ s (microsecond) period for one cycle?

$$F = 1 \div \text{time} \text{ or } F = 1 \div .000001 \text{ or } F = 1,000,000 \text{ Hz or } 1 \text{ MHz}$$

What is the frequency of a sine wave with a 16.666 millisecond period for one cycle?

$$F = 1 \div \text{time} \text{ or } F = 1 \div .016.666 \text{ or } F = 60.000 \text{ Hz}$$

Peak Voltage vs. RMS:

For a pure sine wave the equivalent RMS value is 0.707 times the peak value. Conversely the peak voltage can be calculated as 1.414 times the RMS Value.

Examples: The peak voltage at a standard 120V RMS AC line voltage outlet is $1.414 \times 120\text{V}$ or approx. 170 volts peak. The peak to peak (maximum negative to maximum positive peaks) would be two times the peak voltage or approx. 340 V Peak to Peak.

Peak = RMS Voltage x 1.414 or Peak = 120 x 1.414 or Peak = 169.7 Volts

*PP = 2x Peak or PP = 2 x (120 x 1.414) or PP = 2 x 169.7 or
PP = 339.4 Volts*

Wavelength:

Wave length is the distance a wave will travel during one cycle usually expressed in meters. Light travels and approximately 300 million meters per second (actual speed is 299 792 458 meters every second) Wavelength is important in amateur radio when designing and building antennas.

We frequently refer to the frequency bands in amateur radio by their wavelength in meters. For instance 146 Megahertz (MHz) would be the 2 meter band. Wavelength is easily calculated as using the following equation by dividing 300,000,000 by the frequency in Hertz (or *300 divided by the frequency in Megahertz*).

$$WL = 300,000,000 \div 146,000,000 \text{ or } WL = 2.054 \text{ meters}$$

This is an important equation to remember since there are questions in the exam relating to wave length for a specific frequency or the frequency for a given wavelength.

$$\text{Wavelength (in meters)} = 300 \div \text{Frequency (in megahertz)}$$



Power or work done by electricity:

Power consumed by loads on the electrical system is expressed in Watts and is calculated by multiplying the DC voltage (or RMS voltage for AC) by the current.

How much power is consumed by a 10 ampere load placed on a 12 volt DC power supply?

$$\text{Power} = 12 \text{ volts} \times 10 \text{ amperes} \text{ or } \text{power} = 120 \text{ watts}$$

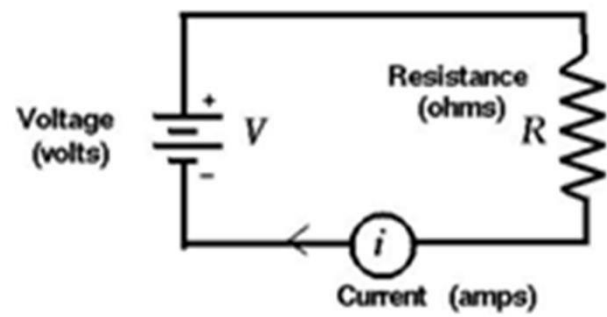

How much power would an electric Iron connected to a 120 RMS AC voltage dissipate if the current flow was 10 amperes?

$$\text{Power} = \text{Current} \times \text{the Voltage} \text{ or } \text{Power} = 10 \times 120 \text{ or } \text{Power} = 1200 \text{ Watts}$$



RF Signals and Modulation

Radio frequencies are simply sine at a much higher frequency. RF signals in the AM Broadcast band are operating from 500,000 hertz to 1,700,000 Hertz. This frequency range can be expressed in kilohertz (thousands of hertz) as 500 KHz to 1,700 KHz , or in megahertz (millions of hertz) as .500 MHz to 1.700 MHz. In the 2 meter band the frequency of the sine waves would be 146,000,000 Hertz or 146 Megahertz. The frequencies noted above are the just the carrier frequency. When we add voice or data to the carrier we are “modulating” the carrier frequency with that information. Modulation can be accomplished by varying the frequency of the carrier (Frequency Modulation or FM) or varying the amplitude of the carrier (Amplitude Modulation or AM) as shown below:

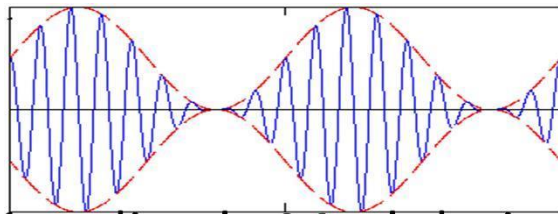

Amplitude Modulation (AM)

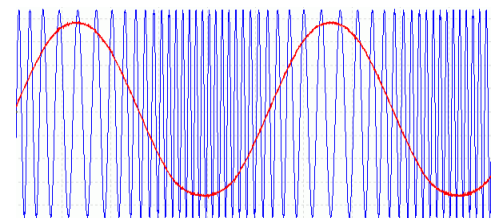

Frequency Modulation

RF Signals and wavelength

We can refer to an alternating waveform in terms of frequency or the distance it will travel in one cycle. Radio frequencies travel at the speed of light which is approximately 300,000,000 meters in one second. .

A frequency of 1Megahertz (1,000,000 Hertz) which is in the middle of the AM broadcast band will travel 300 meters in one complete cycle

$$300,000,000 \div 1,000,000 \text{ or } 300 \div 1 \text{ or } 300 \text{ meters}$$

In amateur radio we frequently refer to our frequencies in terms of approximate wavelength. Since we frequently operating in the megahertz and we can simplify our conversion to wavelength by dividing 300 by the frequency in megahertz (MHz). For example:

A 146 MHz signal would be in the 2 meter band or $300 \div 146 = 2.054$ meters

A 4.0 MHz signal would be in the 75 meter band or $300 \div 4 = 75$ meters

A 50 MHz Signal would be in the 6 meter band or $300 \div 50 = 6$ meters



let's get started.



ELEMENT E1

COMMISSION'S RULES

[6 Exam Questions - 6 Groups]

Element 1 sub-Element 1

E1A01 (D) [97.301, 97.305]

When using a transceiver that displays the carrier frequency of phone signals, which of the following displayed frequencies represents the highest frequency at which a properly adjusted USB emission will be totally within the band? **3 kHz below the upper band edge**

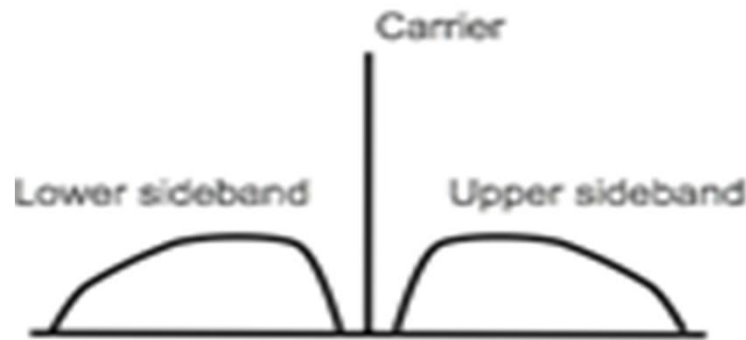

E1A02 (D) [97.301, 97.305]

When using a transceiver that displays the carrier frequency of phone signals, which of the following displayed frequencies represents the lowest frequency at which a properly adjusted LSB emission will be totally within the band? **3 kHz above the lower band edge**

E1A03 (C) [97.301, 97.305]

With your transceiver displaying the carrier frequency of phone signals, you hear a station calling CQ on 14.349 MHz USB. Is it legal to return the call using upper sideband on the same frequency? **No, the sideband will extend beyond the band edge**
The upper side band transmission will be between 14.349 and 14.352. The upper band limit for 20 meters is 14.350 MHz. You would be 2 KHz above the band edge.

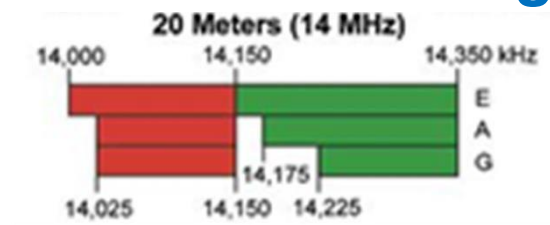

E1A04 (C) [97.301, 97.305]

With your transceiver displaying the carrier frequency of phone signals, you hear a DX station calling CQ on 3.601 MHz LSB. Is it legal to return the call using lower sideband on the same frequency? **No, the sideband will extend beyond the edge of the phone band segment**

The 3.601 MHz LSB signal will go from 3.598 to 3.601 MHz which will be 2 KHz into the CW, RTTY and data portion of the band.

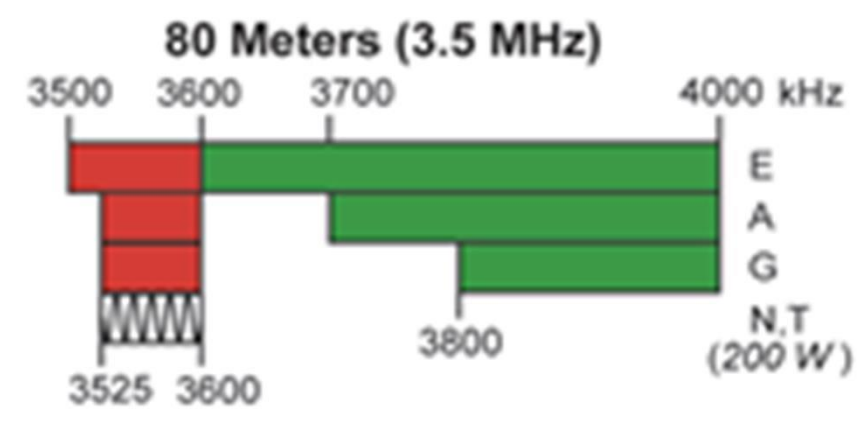

E1A05 (C) [97.313]

What is the maximum power output permitted on the 60 meter band?
100 watts PEP effective radiated power relative to the gain of a half-wave dipole

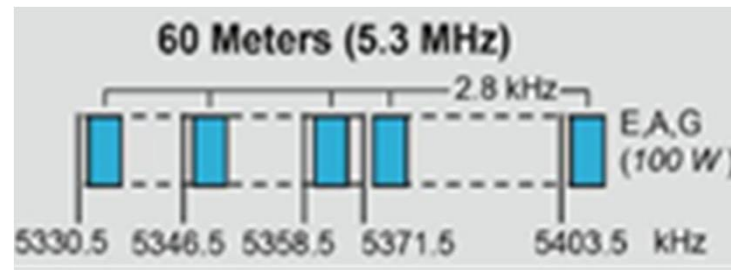

E1A06 (B) [97.15]

Where must the carrier frequency of a CW signal be set to comply with FCC rules for 60 meter operation? **At the center frequency of the channel**

The channel center frequencies are: Channel 1: 5332.0 kHz, Channel 2: 5348.0 kHz, Channel 3: 5358.5 kHz, Channel 4: 5373.0 kHz, and Channel 5: 5405.0 kHz

E1A07 (D) [97.303]

Which amateur band requires transmission on specific channels rather than on a range of frequencies? **60 meter band**

E1A08 (B) [97.219]

If a station in a message forwarding system inadvertently forwards a message that is in violation of FCC rules, who is primarily accountable for the rules violation? **The control operator of the originating station**

E1A09 (A) [97.219]

What is the first action you should take if your digital message forwarding station inadvertently forwards a communication that violates FCC rules? **Discontinue forwarding the communication as soon as you become aware of it**

E1A10 (A) [97.11]

If an amateur station is installed aboard a ship or aircraft, what condition must be met before the station is operated? **Its operation must be approved by the master of the ship or the pilot in command of the aircraft**



E1A11 (B) [97.5]

Which of the following describes authorization or licensing required when operating an amateur station aboard a U.S.-registered vessel in international waters? **Any FCC-issued amateur license**

E1A12 (C) [97.301, 97.305]

With your transceiver displaying the carrier frequency of CW signals, you hear a DX station's CQ on 3.500 MHz. Is it legal to return the call using CW on the same frequency? **No, one of the sidebands of the CW signal will be out of the band**
The 3.500 MHz CW signal will go above and below the 3.500 MHz carrier frequency. The lower sideband portion of the signal will be below 3.500 MHz will be out of band.

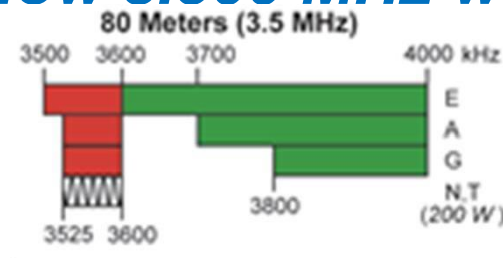

E1A13 (B) [97.5]

Who must be in physical control of the station apparatus of an amateur station aboard any vessel or craft that is documented or registered in the United States? **Any person holding an FCC issued amateur license or who is authorized for alien reciprocal operation**

E1A14 (D) [97.303]

What is the maximum bandwidth for a data emission on 60 meters? **2.8 kHz**

Element 1 Sub-Element B

E1B01 (D) [97.3]

Which of the following constitutes a spurious emission? **An emission outside its necessary bandwidth that can be reduced or eliminated without affecting the information transmitted**

E1B02 (D) [97.13]

Which of the following factors might cause the physical location of an amateur station apparatus or antenna structure to be restricted? **The location is of environmental importance or significant in American history, architecture, or culture**

E1B03 (A) [97.13]

Within what distance must an amateur station protect an FCC monitoring facility from harmful interference? **1 mile**

Allegan, Michigan, 42°36'20.1" N. Latitude, 85°57'20.1" W. Longitude

Belfast, Maine, 44°26'42.3" N. Latitude, 69°04'56.1" W. Longitude

Canandaigua, New York, 42°54'48.2" N. Latitude, 77°15'57.9" W. Longitude

Douglas, Arizona, 31°30'02.3" N. Latitude, 109°39'14.3" W. Longitude

Ferndale, Washington, 48°57'20.4" N. Latitude, 122°33'17.6" W. Longitude

Grand Island, Nebraska, 40°55'21.0" N. Latitude, 98°25'43.2" W. Longitude

Kenai, Alaska, 60°43'26.0" N. Latitude, 151°20'15.0" W. Longitude

Kingsville, Texas, 27°26'30.1" N. Latitude, 97°53'01.0" W. Longitude

Laurel, Maryland, 39°09'54.4" N. Latitude, 76°49'15.9" W. Longitude

Livermore, California, 37°43'29.7" N. Latitude, 121°45'15.8" W. Longitude

Powder Springs, Georgia, 33°51'44.4" N. Latitude, 84°43'25.8" W. Longitude

Santa Isabel, Puerto Rico, 18°00'18.9" N. Latitude, 66°22'30.6" W. Longitude

Vero Beach, Florida, 27°36'22.1" N. Latitude, 80°38'05.2" W. Longitude

Waipahu, Hawaii, 21°22'33.6" N. Latitude, 157°59'44.1" W. Longitude

E1B04 (C) [97.13, 1.1305-1.1319]

What must be done before placing an amateur station within an officially designated wilderness area or wildlife preserve, or an area listed in the National Register of Historical Places? **An Environmental Assessment must be submitted to the FCC**

E1B05 (C) [97.3]

What is the National Radio Quiet Zone? **An area surrounding the National Radio Astronomy**
The location the National Radio Astronomy is in Green Bank, West Virginia

E1B06 (A) [97.15]

Which of the following additional rules apply if you are installing an amateur station antenna at a site at or near a public use airport? **You may have to notify the Federal Aviation Administration and register it with the FCC as required by Part 17 of FCC rules**

E1B07 (B) [97.307]

What is the highest modulation index permitted at the highest modulation frequency for angle modulation below 29.0 MHz?

1.0

The modulation index indicates by how much the modulated variable varies around its unmodulated level. It relates to variations in the carrier frequency

$$\textit{Modulation Index} = \Delta\textit{Frequency} / \textit{Frequency of modulation}$$

E1B08 (D) [97.121]

What limitations may the FCC place on an amateur station if its signal causes interference to domestic broadcast reception, assuming that the receivers involved are of good engineering design? **The amateur station must avoid transmitting during certain hours on frequencies that cause the interference**

E1B09 (C) [97.407]

Which amateur stations may be operated under RACES rules? **Any FCC-licensed amateur station certified by the responsible civil defense organization for the area served**



E1B10 (A) [97.407]

What frequencies are authorized to an amateur station operating under RACES rules? **All amateur service frequencies authorized to the control operator**

E1B11 (A) [97.307]

What is the permitted mean power of any spurious emission relative to the mean power of the fundamental emission from a station transmitter or external RF amplifier installed after January 1, 2003 and transmitting on a frequency below 30 MHz? **At least 43 dB below**

For a 100 watt transmitter this would be .005 watts or 5 Milliwatts

Element 1 Sub-Element C

E1C01 (D) [97.3]

What is a remotely controlled station? **A station controlled indirectly through a control link**

E1C02 (A) [97.3, 97.109]

What is meant by automatic control of a station? **The use of devices and procedures for control so that the control operator does not have to be present at a control point**

E1C03 (B) [97.3, 97.109]

How do the control operator responsibilities of a station under automatic control differ from one under local control? **Under automatic control the control operator is not required to be present at the control point**

E1C04 (A)

What is meant by IARP? **An international amateur radio permit that allows U.S. amateurs to operate in certain countries of the Americas**

E1C05 (A) [97.221(c)(1),97.115(c)]

When may an automatically controlled station originate third party communications? **Never**

E1C06 (C) [97.109]

Which of the following statements concerning remotely controlled amateur stations is true? **A control operator must be present at the control point**

E1C07 (C) [97.3]

What is meant by local control? **Direct manipulation of the transmitter by a control operator**

E1C08 (B) [97.213]

What is the maximum permissible duration of a remotely controlled station's transmissions if its control link malfunctions?
3 minutes

E1C09 (D) [97.205]

Which of these ranges of frequencies is available for an automatically controlled repeater operating below 30 MHz?
29.500 MHz - 29.700 MHz

E1C10 (B) [97.113]

What types of amateur stations may automatically retransmit the radio signals of other amateur stations?

Only auxiliary, repeater or space stations

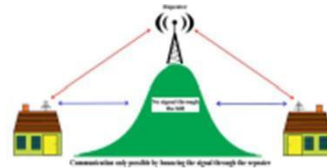

E1C11 (A) [97.5]

Which of the following operating arrangements allows an FCC-licensed U.S. citizen to operate in many European countries, and alien amateurs from many European countries to operate in the U.S.?

CEPT agreement

European Conference of Postal and Telecommunications Administrations (CEPT)

E1C12 (C) [97.117]

What types of communications may be transmitted to amateur stations in foreign countries?

Communications incidental to the purpose of the amateur service and remarks of a personal nature

E1C13 (C)

Which of the following is required in order to operate in accordance with CEPT rules in foreign countries where permitted?

You must bring a copy of FCC

Public Notice DA 11-221

You must also have proof of US citizenship and a copy of your FCC License

Element 1 Sub-Element D

E1D01 (A) [97.3]

What is the definition of the term telemetry? **One-way transmission of measurements at a distance from the measuring instrument**

E1D02 (C) [97.3]

What is the amateur satellite service? **A radio communications service using amateur radio stations on satellites**

E1D03 (B) [97.3]

What is a telecommand station in the amateur satellite service?

An amateur station that transmits communications to initiate, modify or terminate functions of a space station

E1D04 (A) [97.3]

What is an Earth station in the amateur satellite service?

An amateur station within 50 km of the Earth's surface intended for communications with amateur stations by means of objects in space

E1D05 (C) [97.207]

What class of licensee is authorized to be the control operator of a space station? **Any class with appropriate operator privileges**

E1D06 (A) [97.207]

Which of the following is a requirement of a space station? **The space station must be capable of terminating transmissions by telecommand when directed by the FCC**

E1D07 (A) [97.207]

Which amateur service HF bands have frequencies authorized for space stations? **Only the 40 m, 20 m, 17 m, 15 m, 12 m and 10 m bands**

E1D08 (D) [97.207]

Which VHF amateur service bands have frequencies available for space stations? **2 meters**

E1D09 (B) [97.207]

Which UHF amateur service bands have frequencies available for a space station? **70 cm and 13 cm**

E1D10 (B) [97.211]

Which amateur stations are eligible to be telecommand stations? **Any amateur station so designated by the space station licensee, subject to the privileges of the class of operator license held by the control operator**

E1D11 (D) [97.209]

Which amateur stations are eligible to operate as Earth stations? **Any amateur station, subject to the privileges of the class of operator license held by the control operator**

Element 1 Sub-Element E

E1E01 (D) [97.509]

What is the minimum number of qualified VEs required to administer an Element 4 amateur operator license examination? **3**

E1E02 (C) [97.523]

Where are the questions for all written U.S. amateur license examinations listed? **In a question pool maintained by all the VECs**

E1E03 (C) [97.521]

What is a Volunteer Examiner Coordinator? **An organization that has entered into an agreement with the FCC to coordinate amateur operator license examinations**

E1E04 (D) [97.509, 97.525]

Which of the following best describes the Volunteer Examiner accreditation process? **The procedure by which a VEC confirms that the VE applicant meets FCC requirements to serve as an examiner**

E1E05 (B) [97.503]

What is the minimum passing score on amateur operator license examinations? **Minimum passing score of 74%**

You must get 37 correct on the 50 question Extra Exam to pass.

E1E06 (C) [97.509]

Who is responsible for the proper conduct and necessary supervision during an amateur operator license examination session? **Each administering VE**

E1E07 (B) [97.509]

What should a VE do if a candidate fails to comply with the examiner's instructions during an amateur operator license examination? **Immediately terminate the candidate's examination**

E1E08 (C) [97.509]

To which of the following examinees may a VE not administer an examination? **Relatives of the VE as listed in the FCC rules**

E1E09 (A) [97.509]

What may be the penalty for a VE who fraudulently administers or certifies an examination?

Revocation of the VE's amateur station license grant and the suspension of the VE's amateur operator license grant

VE1E10 (C) [97.509]

What must the administering VEs do after the administration of a successful examination for an amateur operator license? **They must submit the application document to the coordinating VEC according to the coordinating VEC instructions**

E1E11 (B) [97.509]

What must the VE team do if an examinee scores a passing grade on all examination elements needed for an upgrade or new license? **Three VEs must certify that the examinee is qualified for the license grant and that they have complied with the administering VE requirements**

E1E12 (A) [97.509]

What must the VE team do with the application form if the examinee does not pass the exam? **Return the application document to the examinee**

E1E13 (B) [97.509]

Which of these choices is an acceptable method for monitoring the applicants if a VEC opts to conduct an exam session remotely? **Use a real-time video link and the Internet to connect the exam session to the observing VEs**

E1E14 (A) [97.527]

For which types of out-of-pocket expenses do the Part 97 rules state that VEs and VECs may be reimbursed? **Preparing, processing, administering and coordinating an examination for an amateur radio license**

Element 1 Sub-Element F

E1F01 (B) [97.305]

On what frequencies are spread spectrum transmissions permitted? **Only on amateur frequencies above 222 MHz**

E1F02 (C) [97.107]

What privileges are authorized in the U.S. to persons holding an amateur service license granted by the Government of Canada? **The operating terms and conditions of the Canadian amateur service license, not to exceed U.S. Extra Class privileges**

E1F03 (A) [97.315]

Under what circumstances may a dealer sell an external RF power amplifier capable of operation below 144 MHz if it has not been granted FCC certification?

It was purchased in used condition from an amateur operator and is sold to another amateur operator for use at that operator's station

It

E1F04 (A) [97.3]

Which of the following geographic descriptions approximately describes "Line A"? **A line roughly parallel to and south of the U.S.-Canadian border**

No amateur station shall transmit from north of Line A in the 420-430 MHz segment. See §97.3(a) for the definition of Line A.



E1F05 (D) [97.303]

Amateur stations may not transmit in which of the following frequency segments if they are located in the contiguous 48 states and north of Line A? **420 MHz - 430 MHz**

E1F06 (A) [1.931]

Under what circumstances might the FCC issue a Special Temporary Authority (STA) to an amateur station? **To provide for experimental amateur communications**

E1F07 (D) [97.113]

When may an amateur station send a message to a business? **When neither the amateur nor his or her employer has a pecuniary (monetary) interest in the communications**

E1F08 (A) [97.113]

Which of the following types of amateur station communications are prohibited? **Communications transmitted for hire or material compensation, except as otherwise provided in the rules**

E1F09 (D) [97.311]

Which of the following conditions apply when transmitting spread spectrum emission?

- A. A station transmitting SS emission must not cause harmful interference to other stations employing other authorized emissions**
- B. The transmitting station must be in an area regulated by the FCC or in a country that permits SS emissions**
- C. The transmission must not be** used to obscure the meaning of any communication
- D. All of these choices are correct**

E1F10 (C) [97.313]

What is the maximum permitted transmitter peak envelope power for an amateur station transmitting spread spectrum communications? **10 Watts**

E1F11 (D) [97.317]

Which of the following best describes one of the standards that must be met by an external RF power amplifier if it is to qualify for a grant of FCC certification? **It must satisfy the FCC's spurious emission standards when operated at the lesser of 1500 watts or its full output power**

E1F12 (B) [97.201]

Who may be the control operator of an auxiliary station? **Only Technician, General, Advanced or Amateur Extra Class operators**

ELEMENT E2

OPERATING PROCEDURES

[5 Exam Questions - 5 Groups]

Element 2 Sub-Element A

E2A01 (C)

What is the direction of an ascending pass for an amateur satellite? **From south to north**

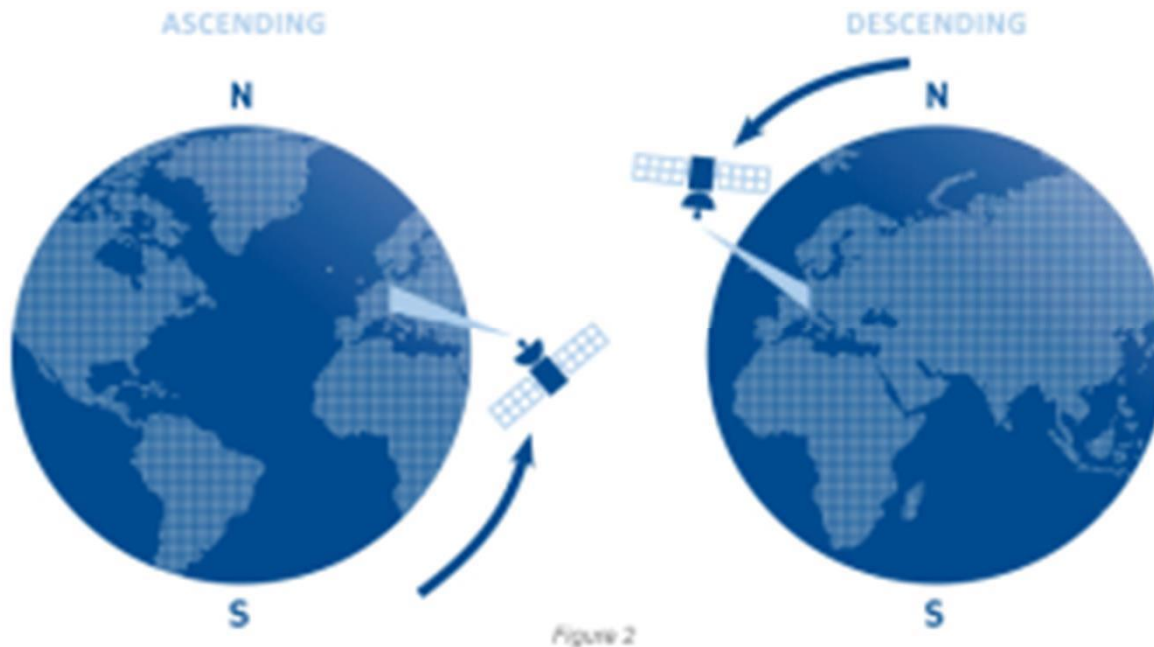

E2A02 (A)

What is the direction of a descending pass for an amateur satellite? **From north to south**

E2A03 (C)

What is the orbital period of an Earth satellite? **The time it takes for a satellite to complete one revolution around the Earth**

E2A04 (B)

What is meant by the term mode as applied to an amateur radio satellite? **The satellite's uplink and downlink frequency bands**

E2A05 (D)

What do the letters in a satellite's mode designator specify? **The uplink and downlink frequency ranges**

U/V mode = UHF uplink and VHF downlink

V/U mode = VHF uplink and UHF Downlink

E2A06 (A)

On what band would a satellite receive signals if it were operating in mode U/V? **435 MHz - 438 MHz**

E2A07 (D)

Which of the following types of signals can be relayed through a linear transponder?

A. FM and CW

B. SSB and SSTV

C. PSK and Packet

D. All of these choices are correct

E2A08 (B)

Why should effective radiated power to a satellite which uses a linear transponder be limited? **To avoid reducing the downlink power to all other users**

E2A09 (A)

What do the terms L band and S band specify with regard to satellite communications? **The 23 centimeter and 13 centimeter bands**

L Band	1 - 2 GHz
S Band	2-4 GHz
C Band	4- 8 GHz
X Band	8-12 GHz
Ku Band	12-18 GHz
K Band	18-27 GHz

E2A10 (A)

Why may the received signal from an amateur satellite exhibit a rapidly repeating fading effect? **Because the satellite is spinning**

This means the antenna polarization is changing vs time as the satellite and antenna rotates

E2A11 (B)

What type of antenna can be used to minimize the effects of spin modulation and Faraday rotation?

A circularly polarized antenna

E2A12 (D)

What is one way to predict the location of a satellite at a given time? **By calculations using the Keplerian elements for the specified satellite**

Sample Keplerian elements for AO-07 Amateur Satellite:

*1 7530U 74089B 16039.93794353 -.00000053
+00000-0 -58321-4 0 9998*

*2 7530 101.5575 013.9321 0011807 201.1018
226.0052 12.53619447886696*

E2A13 (B)

What type of satellite appears to stay in one position in the sky? **Geostationary**

E2A14 (C)

What technology is used to track, in real time, balloons carrying amateur radio transmitters? **APRS**

Automatic Packet Reporting System - Reporting real time position and Altitude from a GPS Receiver. The APRS System can also exchange messages between stations.



Element 2 Sub-Element B

E2B01 (A)

How many times per second is a new frame transmitted in a fast-scan (NTSC) television system? **30**

NTSC is the National Television Standards Committee/. This is the US standard for the old analog TV System.

E2B02 (C)

How many horizontal lines make up a fast-scan (NTSC) television frame? **525**

E2B03 (D)

How is an interlaced scanning pattern generated in a fast-scan (NTSC) television system? **By scanning odd numbered lines in one field and even numbered lines in the next in the next**

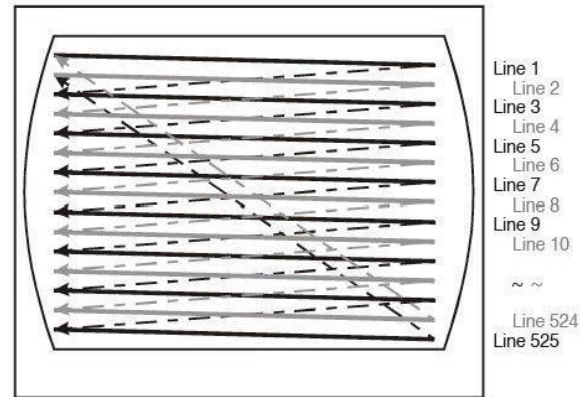

E2B04 (B)

What is blanking in a video signal? **Turning off the scanning beam while it is traveling from right to left or from bottom to top**

E2B04 (B)

What is blanking in a video signal? **Turning off the scanning beam while it is traveling from right to left or from bottom to top**

E2B05 (C)

Which of the following is an advantage of using vestigial sideband for standard fast-scan TV transmissions? **Vestigial sideband reduces bandwidth while allowing for simple video detector circuitry**

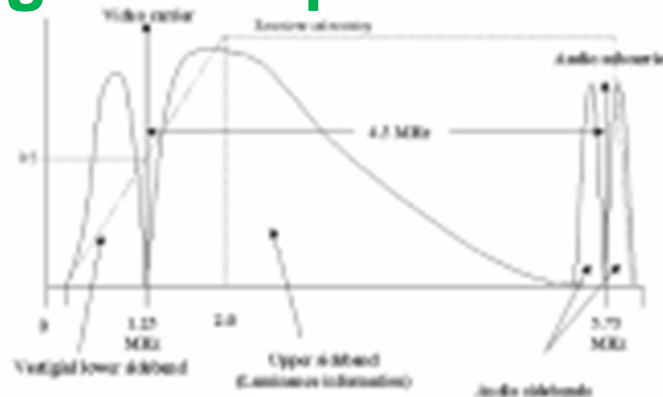

E2B06 (A)

What is vestigial sideband modulation? **Amplitude modulation in which one complete sideband and a portion of the other are transmitted**

E2B07 (B)

What is the name of the signal component that carries color information in NTSC video? **Chroma**

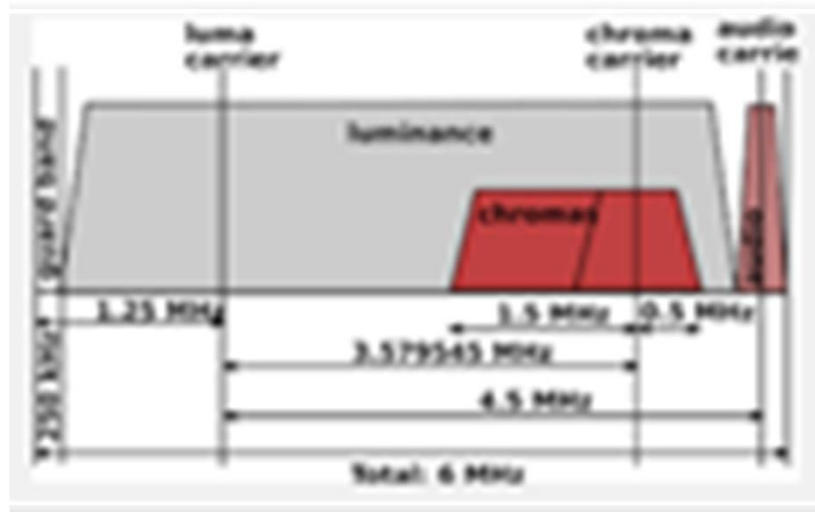

2B08 (D)

Which of the following is a common method of transmitting accompanying audio with amateur fast-scan television?

- A. Frequency-modulated sub-carrier**
- B. A separate VHF or UHF audio link**
- C. Frequency modulation of the video carrier**
- D. All of these choices are correct**

E2B09 (D)

What hardware, other than a receiver with SSB capability and a suitable computer, is needed to decode SSTV using Digital Radio Mondiale (DRM)? **No other hardware is needed**

Digital Radio Mondiale (abbreviated DRM) is a set of digital audio broadcasting technologies designed to work over the bands currently used for analogue radio broadcasting including AM broadcasting, particularly shortwave, and FM broadcasting. The principle of DRM is that bandwidth is the limited element, and computer processing power is cheap; modern CPU-intensive audio compression techniques enable more efficient use of available bandwidth, at the expense of processing resources.

E2B10 (A)

Which of the following is an acceptable bandwidth for Digital Radio Mondiale (DRM) based voice or SSTV digital transmissions made on the HF amateur bands?

3 KHz

E2B11 (B)

What is the function of the Vertical Interval Signaling (VIS) code sent as part of an SSTV transmission?

To identify the SSTV mode being used

Around 80% of images sent in North America are Scottie S1. You will also hear a few S2, Martin M1, Robot 36 and 72. Others are extremely rare.

E2B12 (D)

How are analog SSTV images typically transmitted on the HF bands? **Varying tone frequencies representing the video are transmitted using single sideband**

E2B13 (C)

How many lines are commonly used in each frame of an amateur slow-scan color television picture?

128 or 256

E2B14 (A)

What aspect of an amateur slow-scan television signal encodes the brightness of the picture? **Tone frequency**

E2B15 (A)

What signals SSTV receiving equipment to begin a new picture line? **Specific tone frequencies**

E2B16 (D)

Which is a video standard used by North American Fast Scan ATV stations? **NTSC**

National Television Standards Committee

E2B17 (B)

What is the approximate bandwidth of a slow-scan TV signal? **3 kHz**

E2B18 (D)

On which of the following frequencies is one likely to find FM ATV transmissions? **1255 MHz**

E2B19 (C)

What special operating frequency restrictions are imposed on slow scan TV transmissions? **They are restricted to phone band segments and their bandwidth can be no greater than that of a voice signal of the same modulation type**

Element 2 Sub-Element C

E2C01 (A)

Which of the following is true about contest operating?
Operators are permitted to make contacts even if they do not submit a log

E2C02 (A)

Which of the following best describes the term self-spotting in regards to HF contest operating? **The generally prohibited practice of posting one's own call sign and frequency on a spotting network**

E2C03 (A)

From which of the following bands is amateur radio contesting generally excluded? **30 meters**

30 meters - Maximum power, 200 watts PEP. Amateurs must avoid interference to the fixed service outside the US. General, Advanced, Amateur Extra class operators. Frequencies from 10.100-10.150 MHz using CW, RTTY and Data

E2C04 (A)

What type of transmission is most often used for a ham radio mesh network? **Spread spectrum in the 2.4 GHz band**

Broadband-Hamnet™ (formerly called HSMM-Mesh™) is a high speed, self-discovering, self-configuring, fault tolerant, wireless computer network that can run for days from a fully charged car battery, or indefinitely with the addition of a modest solar array or other supplemental power source. The focus is on emergency communications.

E2C05 (B)

What is the function of a DX QSL Manager? **To handle the receiving and sending of confirmation cards for a DX station**

E2C06 (C)

During a VHF/UHF contest, in which band segment would you expect to find the highest level of activity? **In the weak signal segment of the band, with most of the activity near the calling frequency**

E2C07 (A)

What is the Cabrillo format? **A standard for submission of electronic contest logs**

E2C08 (B)

Which of the following contacts may be confirmed through the U.S. QSL bureau system? **Contacts between a U.S. station and a non-U.S. station**

E2C09 (C)

What type of equipment is commonly used to implement a ham radio mesh network? **A standard wireless router running custom software**

E2C10 (D)

Why might a DX station state that they are listening on another frequency?

- A. Because the DX station may be transmitting on a frequency that is prohibited to some responding stations**
- B. To separate the calling stations from the DX station**
- C. To improve operating efficiency by reducing interference**
- D. All of these choices are correct**

E2C11 (A)

How should you generally identify your station when attempting to contact a DX station during a contest or in a pileup? **Send your full call sign once or twice**

E2C12 (B)

What might help to restore contact when DX signals become too weak to copy across an entire HF band a few hours after sunset? **Switch to a lower frequency HF band**

E2C13 (D)

What indicator is required to be used by U.S.-licensed operators when operating a station via remote control where the transmitter is located in the U.S.? **No additional indicator is required**

Element 2 Sub-Element D

E2D01 (B)

Which of the following digital modes is especially designed for use for meteor scatter signals? **FSK441**

E2D02 (D)

Which of the following is a good technique for making meteor scatter contacts?

- A. 15 second timed transmission sequences with stations alternating based on location**
- B. Use of high speed CW or digital modes**
- C. Short transmission with rapidly repeated call signs and signal reports**
- D. All of these choices are correct**

E2D03 (D)

Which of the following digital modes is especially useful for EME communications? **JT65**

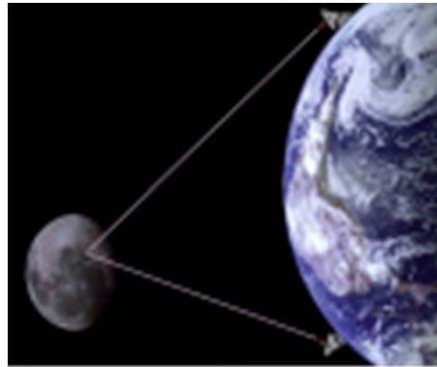

E2D04 (C)

What is the purpose of digital store-and-forward functions on an Amateur Radio satellite? **To store digital messages in the satellite for later download by other stations**

E2D05 (B)

Which of the following techniques is normally used by low Earth orbiting digital satellites to relay messages around the world? **Store-and-forward**

E2D06 (A)

Which of the following describes a method of establishing EME contacts? **Time synchronous transmissions alternately from each station**

All EME communication occurs on specific timed cycles, and as such it is critical that the PC's time is synchronized very accurately (to within less than a second).

E2D07 (C)

What digital protocol is used by APRS? **AX.25**
AX.25 is a data link layer protocol derived from the X.25 protocol suite and designed for use by amateur radio operators.

E2D08 (A)

What type of packet frame is used to transmit APRS beacon data? **Unnumbered Information**

E2D09 (D)

Which of these digital modes has the fastest data throughput under clear communication conditions?

300 baud packet

E2D10 (C)

How can an APRS station be used to help support a public service communications activity? **An APRS station with a GPS unit can automatically transmit information to show a mobile station's position during the event**

E2D11 (D)

Which of the following data are used by the APRS network to communicate your location? **Latitude and longitude**

E2D12 (A)

How does JT65 improve EME communications?

- A. It can decode signals many dB below the noise floor using FEC**
- B. It controls the receiver to track Doppler shift**
- C. It supplies signals to guide the antenna to track the Moon**
- D. All of these choices are correct**

E2D13 (A)

What type of modulation is used for JT65 contacts?

Multi-tone AFSK

Amplitude Frequency Shift Keying

E2D14 (B)

What is one advantage of using JT65 coding? **The ability to decode signals which have a very low signal to noise ratio**

Element 2 Sub-Element E

E2E01 (B)

Which type of modulation is common for data emissions below 30 MHz? **FSK**

Frequency-shift keying is a frequency modulation scheme where digital information is transmitted through discrete frequency changes of a carrier signal. The simplest FSK is binary FSK (BFSK).

E2E02 (A)

What do the letters FEC mean as they relate to digital operation? **Forward Error Correction**

Forward error correction (FEC) or channel coding is a technique used for controlling errors in data transmission over unreliable or noisy communication channels.

E2E03 (C)

How is the timing of JT65 contacts organized?
Alternating transmissions at 1 minute intervals

E2E04 (A)

What is indicated when one of the ellipses in an FSK crossed-ellipse display suddenly disappears? **Selective fading has occurred**



E2E05 (A)

Which type of digital mode does not support keyboard-to-keyboard operation? **Winlink**

E2E06 (C)

What is the most common data rate used for HF packet? **300 baud**

E2E07 (B)

What is the typical bandwidth of a properly modulated MFSK16 signal? **316 Hz**

E2E08 (B)

Which of the following HF digital modes can be used to transfer binary files? **PACKTOR**

E2E09 (D)

Which of the following HF digital modes uses variable-length coding for bandwidth efficiency? **PSK31**

E2E10 (C)

Which of these digital modes has the narrowest bandwidth? **PSK31**

E2E11 (A)

What is the difference between direct FSK and audio FSK? **Direct FSK applies the data signal to the transmitter VFO**

E2E12 (C)

Which type of control is used by stations using the Automatic Link Enable (ALE) protocol?

Automatic

E2E13 (D)

Which of the following is a possible reason that attempts to initiate contact with a digital station on a clear frequency are unsuccessful?

A. Your transmit frequency is incorrect

B. The protocol version you are using is not the supported by the digital station

C. Another station you are unable to hear is using the frequency

D. All of these choices are correct

ELEMENT E3
RADIO WAVE PROPAGATION
[3 Exam Questions - 3 Groups]

Element 3 Sub-Element A

E3A01 (D)

What is the approximate maximum separation measured along the surface of the Earth between two stations communicating by Moon bounce? **12,000 miles, if the Moon is visible by both**



E3A02 (B)

What characterizes libration fading of an EME signal?

A fluttery irregular fading

Libration fading caused by multipath effects of rough lunar surface and relative motion between the earth and the moon, It is a rapid, deep and irregular Fading of 20 dB or more

E3A03 (A)

When scheduling EME contacts, which of these conditions will generally result in the least path loss?

When the Moon is at perigee

Perigee is when the moon is closest to earth during its monthly orbit

E3A04 (D)

What do Hepburn maps predict? **Probability of tropospheric propagation**

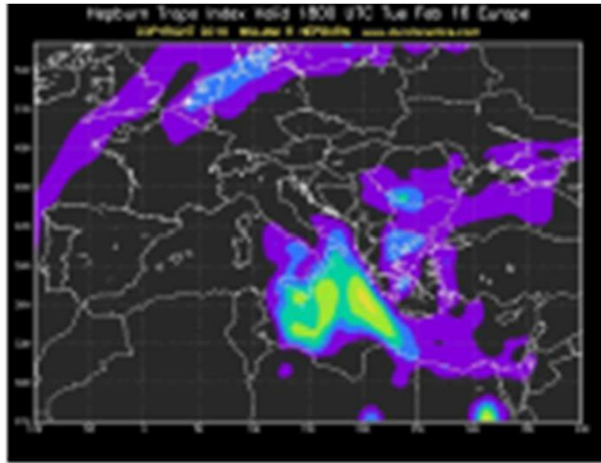

E3A05 (C)

Tropospheric propagation of microwave signals often occurs along what weather related structure?

Warm and cold fronts

E3A06 (C)

Which of the following is required for microwave propagation via rain scatter? **The rain must be within radio range of both stations**

Rain scattering is purely a microwave propagation mode and is best observed around 10 GHz, but extends down to a few gigahertz; the limit being the size of the scattering particle size vs. wavelength. Forward-scattering typically yields propagation ranges of 800 km (approx.500 miles).

E3A07 (C)

Atmospheric ducts capable of propagating microwave signals often form over what geographic feature?

Bodies of water

an atmospheric duct is a horizontal layer in the lower atmosphere in which the vertical refractive index gradients are such that radio signals are guided or ducted, tend to follow the curvature of the Earth, and experience less attenuation in the ducts than they would if the ducts were not present. The duct acts as an atmospheric dielectric waveguide.

E3A08 (A)

When a meteor strikes the Earth's atmosphere, a cylindrical region of free electrons is formed at what layer of the ionosphere? **The E layer**

E3A09 (C)

Which of the following frequency range is most suited for meteor scatter communications? **28 MHz - 148 MHz**

E3A10 (B)

Which type of atmospheric structure can create a path for microwave propagation?

Temperature inversion

E3A11 (B)

What is a typical range for tropospheric propagation of microwave signals? **100 miles to 300 miles**

E3A12 (C)

What is the cause of auroral activity? **The interaction in the E layer of charged particles from the Sun with the Earth's magnetic field**

E3A13 (A)

Which emission mode is best for aurora propagation?
CW

E3A14 (B)

From the contiguous 48 states, in which approximate direction should an antenna be pointed to take maximum advantage of aurora propagation? **North**

E3A15 (C)

What is an electromagnetic wave? **A wave consisting of an electric field and a magnetic field oscillating at right angles to each other**

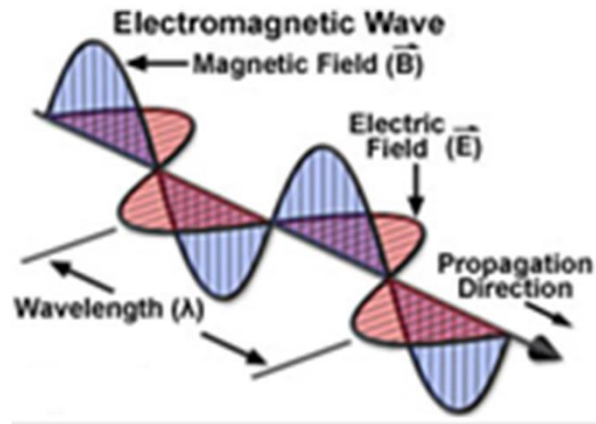

E3A16 (D)

Which of the following best describes electromagnetic waves traveling in free space? **Changing electric and magnetic fields propagate the energy**

E3A17 (B)

What is meant by circularly polarized electromagnetic waves? **Waves with a rotating electric field**

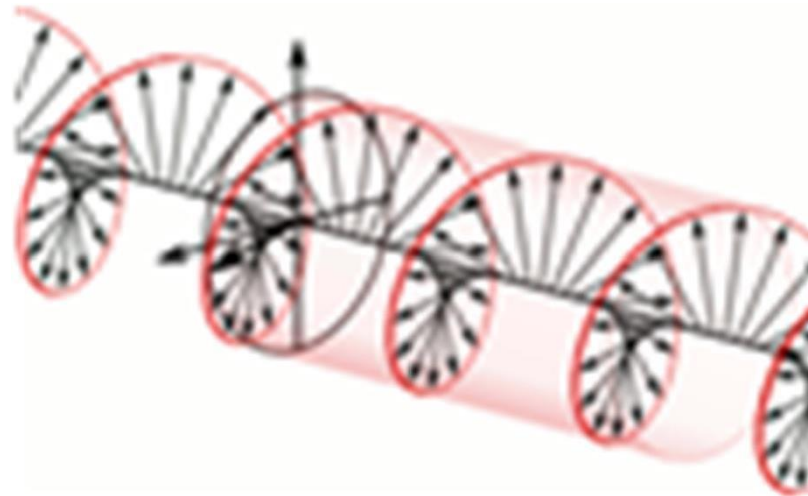

Element 3 Sub-Element B

E3B01 (A)

What is transequatorial propagation?

Propagation between two mid-latitude points at approximately the same distance north and south of the magnetic equator

- 1. The first type occurs during the late afternoon / early evening hours and is generally limited to distances of 5,000-6,000 miles. Signals propagated by this mode are limited to the low VHF band (<60 MHz), are of high signal strength and suffer moderate distortion (due to multipath). Single sideband voice communications are possible with this mode.*
- 2. The second type of TEP occurs from around 1900 to 2300 hours local time. Contacts can be made at 144 MHz, and even very rarely on 432 MHz. The signal strength is moderately high, but subject to intense rapid fading, making Morse Code the only possible communication mode.*

E3B02 (C)

What is the approximate maximum range for signals using transequatorial propagation? **5000 miles**

E3B03 (C)

What is the best time of day for transequatorial propagation? **Afternoon or early evening**

E3B04 (B)

What is meant by the terms extraordinary and ordinary waves? **Independent waves created in the**

ionosphere that are elliptically polarized

In Elliptical polarization is the polarization the tip of the electric field describes an ellipse in any fixed plane intersecting, and normal to, the direction of propagation.

E3B05 (C)

Which amateur bands typically support long-path propagation? **160 meters to 10 meters**

E3B06 (B)

Which of the following amateur bands most frequently provides long-path propagation? **20 meters**

E3B07 (D)

Which of the following could account for hearing an echo on the received signal of a distant station?

Receipt of a signal by more than one path

This could be a long path signal traveling around the world or a reflected signal

E3B08 (D)

What type of HF propagation is probably occurring if radio signals travel along the terminator between daylight and darkness? **Gray-line**

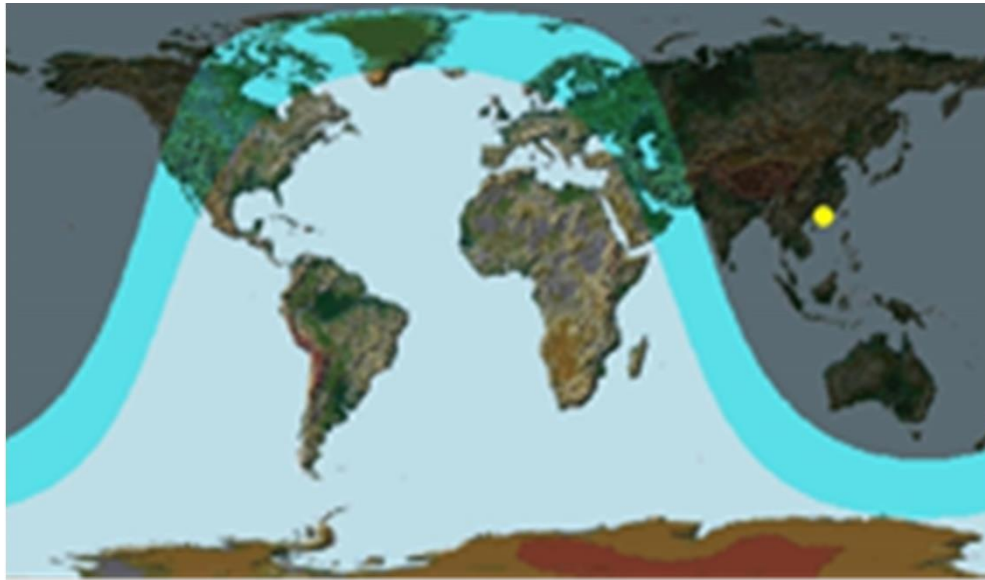

E3B09 (A)

At what time of year is Sporadic E propagation most likely to occur? **Around the solstices, especially the summer solstice**

E3B10 (B)

What is the cause of gray-line propagation? **At twilight and sunrise, D-layer absorption is low while E-layer and F-layer propagation remains high**

E3B12 (B)

What is the primary characteristic of chordal hop propagation? **Successive ionospheric reflections without an intermediate reflection from the ground**

CHORDAL HOP is where the signal bounces from the upper ionosphere without sufficient strength to return to earth. The signal becomes 'trapped' between the lower and upper levels of the ionosphere and bounces, or hops, within the ionosphere. Eventually, the signal strikes the upper layers at an angle sufficient to allow it to penetrate the lower levels of the ionosphere and return to earth.

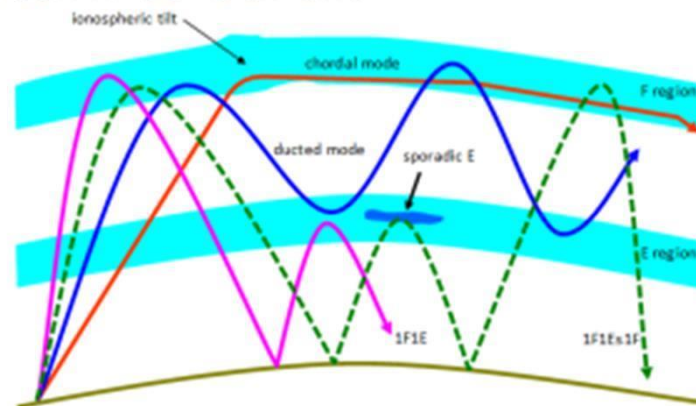

E3B13 (A)

Why is chordal hop propagation desirable? **The signal experiences less loss along the path compared to normal skip propagation**

The advantage of chordal hopping is that the signal suffers much less attenuation than if it were to return to earth each time before bouncing to the higher ionospheric levels.

E3B14 (C)

What happens to linearly polarized radio waves that split into ordinary and extraordinary waves in the ionosphere? **They become elliptically polarized**

Element 3 Sub-Element C

E3C01 (B)

What does the term ray tracing describe in regard to radio communications? **Modeling a radio wave's path through the ionosphere**

E3C03 (B)

Which of the following signal paths is most likely to experience high levels of absorption when the A index or K index is elevated? **Polar paths**

E3C04 (C)

What does the value of B_z (B sub Z) represent?

Direction and strength of the interplanetary magnetic field

When B_z is south, that is, opposite Earth's magnetic field, the two fields link up," Southward B_z 's often herald widespread auroras, triggered by solar wind gusts or coronal mass ejections that are able to inject energy into our planet's magnetosphere.

E3C05 (A)

What orientation of B_z ($B_{\text{sub } z}$) increases the likelihood that incoming particles from the Sun will cause disturbed conditions? **Southward**

E3C06 (A)

By how much does the VHF/UHF radio horizon distance exceed the geometric horizon?

By approximately 15 percent of the distance

E3C07 (D)

Which of the following descriptors indicates the greatest solar flare intensity? **Class X**

Solar flares are giant explosions on the sun that send energy into space. These flares are often associated with solar magnetic storms or coronal mass ejections (CMEs).

The biggest flares are known as "X-class flares" The smallest ones are A-class, followed by B, C, M and X. Similar to the Richter scale for earthquakes, each letter represents a 10-fold increase in energy output. So an X is ten times an M and 100 times a C. The biggest X-class flares are by far the largest explosions in the solar system. Loops tens of times the size of Earth leap up off the sun's surface when the sun's magnetic fields cross over each other and reconnect. This reconnection process can produce as much energy as a billion hydrogen bombs.

E3C08 (A)

What does the space weather term G5 mean? **An extreme geomagnetic storm**

E3C09 (C)

How does the intensity of an X3 flare compare to that of an X2 flare? **Twice as great**

E3C10 (B)

What does the 304A solar parameter measure? **UV Emissions at 304 angstroms, correlated to solar flux index**

The angstrom is a unit of length equal to 10^{-10} m or 0.1 nm. This is a light wavelength in the infrared region.

E3C11 (C)

What does VOACAP software model? **HF propagation**

E3C12 (C)

How does the maximum distance of ground-wave propagation change when the signal frequency is increased? **It decreases**

E3C13 (A)

What type of polarization is best for ground-wave propagation? **Vertical**

E3C14 (D)

Why does the radio-path horizon distance exceed the geometric horizon? **Downward bending due to density variations in the atmosphere**

E3C15 (B)

What might a sudden rise in radio background noise indicate? **A solar flare has occurred**

SUBELEMENT E4
AMATEUR PRACTICES

[5 Exam Questions - 5 Groups]

Element 4 Sub-Element A

E4A01 (C)

Which of the following parameter determines the bandwidth of a digital or computer-based oscilloscope?

Sampling rate

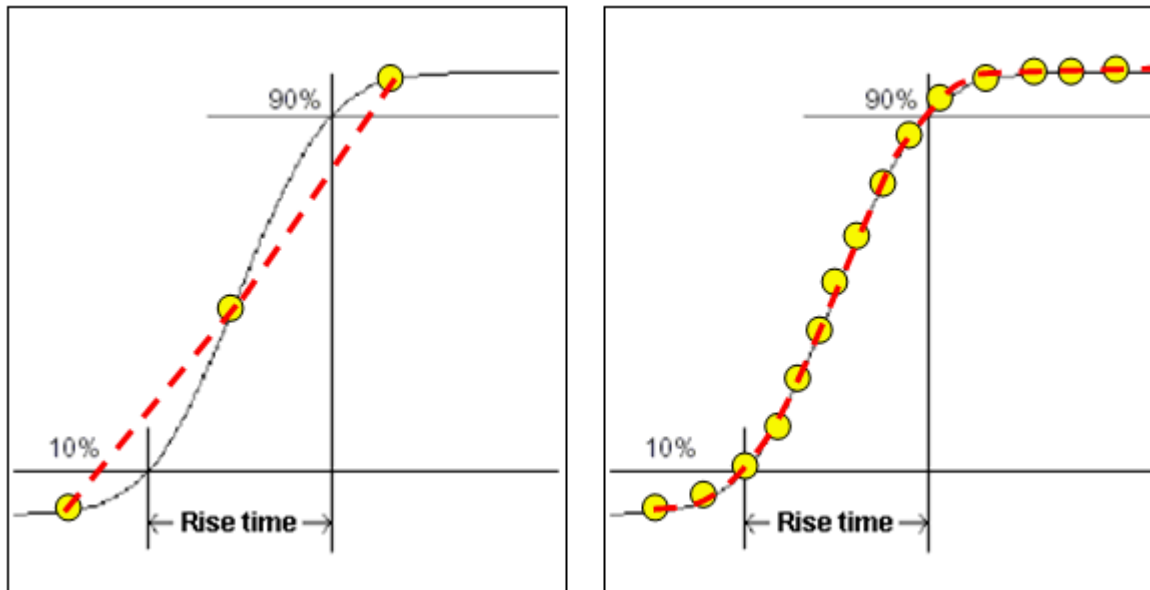

E4A02 (B)

Which of the following parameters would a spectrum analyzer display on the vertical and horizontal axes?

RF amplitude and frequency

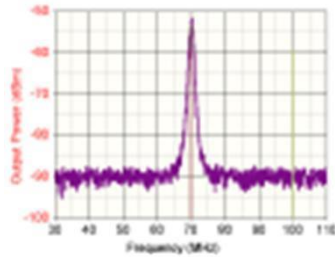

E4A03 (B)

Which of the following test instrument is used to display spurious signals and/or intermodulation distortion products in an SSB transmitter?

A spectrum analyzer

A spectrum analyzer

E4A05 (D)

What might be an advantage of a digital vs an analog oscilloscope?

A. Automatic amplitude and frequency numerical readout

B. Storage of traces for future reference

C. Manipulation of time base after trace capture

D. All of these choices are correct

E4A06 (A)

What is the effect of aliasing in a digital or computer-based oscilloscope? **False signals are displayed**

Aliasing is a signal processing term. Aliasing occurs when a system is measured at an insufficient sampling rate. Aliasing occurs when you sample a signal (anything which repeats a cycle over time) too slowly and obtain an incorrect frequency and/or amplitude as a result.

E4A07 (B)

Which of the following is an advantage of using an antenna analyzer compared to an SWR bridge to measure antenna SWR? **Antenna analyzers do not need an external RF source**



E4A08 (D)

Which of the following instrument would be best for measuring the SWR of a beam antenna?

An antenna analyzer

E4A09 (B)

When using a computer's soundcard input to digitize signals, what is the highest frequency signal that can be digitized without aliasing? **One-half the sample rate**

E4A10 (D)

Which of the following displays multiple digital signal states simultaneously? **Logic analyzer**

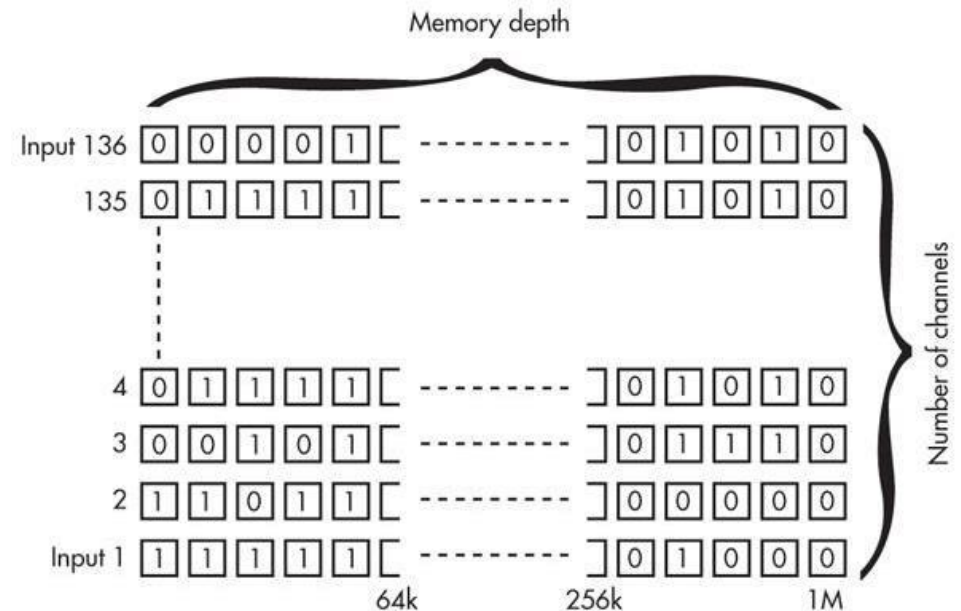
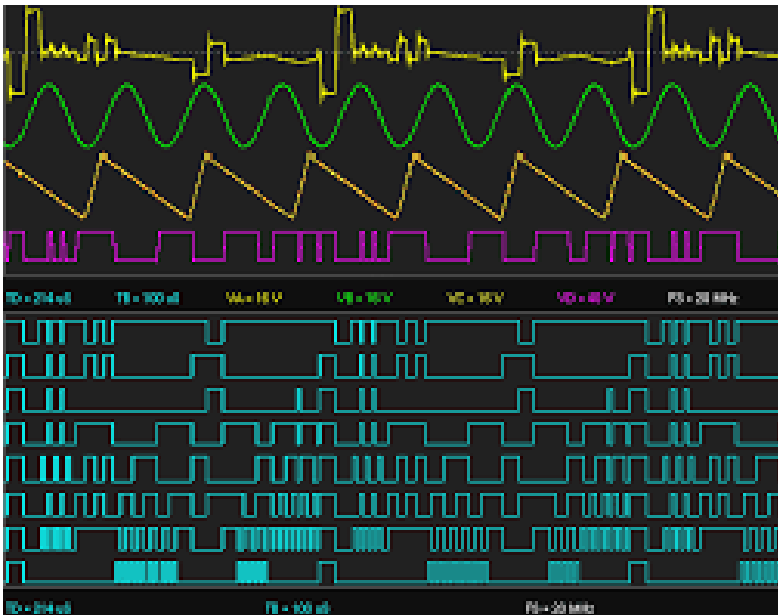

E4A11 (A)

Which of the following is good practice when using an oscilloscope probe? **Keep the signal ground connection of the probe as short as possible**

Keep the signal ground connection of the probe as short as possible

Extended leads look like inductance and can cause measurement errors of RF signals.

E4A12 (B)

Which of the following procedures is an important precaution to follow when connecting a spectrum analyzer to a transmitter output? **Attenuate the transmitter output going to the spectrum analyzer**

Direct connections can destroy the spectrum analyzer

E4A13 (A)

How is the compensation of an oscilloscope probe typically adjusted? **A square wave is displayed and the probe is adjusted until the horizontal portions of the displayed wave are as nearly flat as possible**

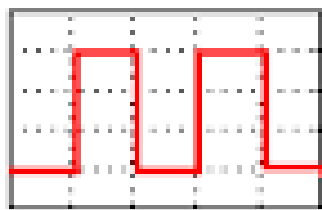

t (s)
correctly
compensated

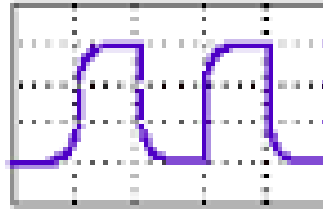

t (s)
under-
compensated

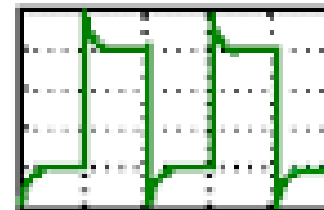

t (s)
over-
compensated

E4A14 (D)

What is the purpose of the prescaler function on a frequency counter? **It divides a higher frequency signal so a low-frequency counter can display the input frequency**

E4A15 (C)

What is an advantage of a period-measuring frequency counter over a direct-count type? **It provides improved resolution of low-frequency signals within a comparable time period**

In the period measurement mode the incoming signal becomes the gate control and the time base is counted for the period of time the gate is open. For a one hertz signal and a one MHz time base the one hertz signal can be measured with one micro hertz resolution.

Element 4 Sub-Element B

E4B01 (B)

Which of the following factors most affects the accuracy of a frequency counter? **Time base accuracy**

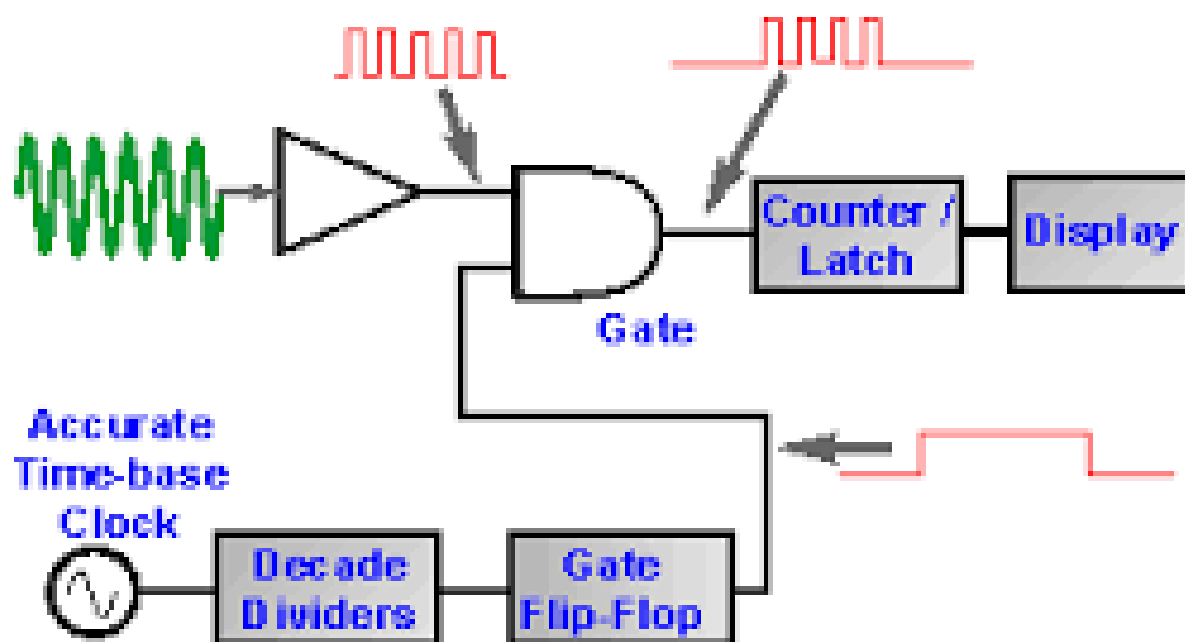

E4B02 (C)

What is an advantage of using a bridge circuit to measure impedance? **It is very precise in obtaining a signal null**



E4B03 (C)

If a frequencies counter with a specified accuracy of **+/- 1.0 ppm** reads 146,520,000 Hz, what is the most the actual frequency being measured could differ from the reading? **146.52 Hz**

0.000,001 x 146,520,000 Hz or 146.52 Hz

E4B03 (C)

If a frequencies counter with a specified accuracy of **+/- 1.0 ppm** reads 146,520,000 Hz, what is the most the actual frequency being measured could differ from the reading? **146.52 Hz**

0.000,001 x 146,520,000 Hz or 146.52 Hz

E4B04 (A)

If a frequency counter with a specified accuracy of **+/- 0.1 ppm** reads 146,520,000 Hz, what is the most the actual frequency being measured could differ from the reading? **14.652 Hz**

0.000,000,1 x 146,520,000 Hz or 14.652Hz

E4B05 (D)

If a frequency counter with a specified accuracy of **+/- 10 ppm** reads 146,520,000 Hz, what is the most the actual frequency being measured could differ from the reading? **1465.20 Hz**

0.000,01 x 146,520,000 Hz or 1465.20 Hz

E4B06 (D)

How much power is being absorbed by the load when a directional power meter connected between a transmitter and a terminating load reads 100 watts forward power and 25 watts reflected power? **75 watts**

100 watts – 25 watts = 75 watts

E4B07 (A)

What do the subscripts of S parameters represent? **The port or ports at which measurements are made**

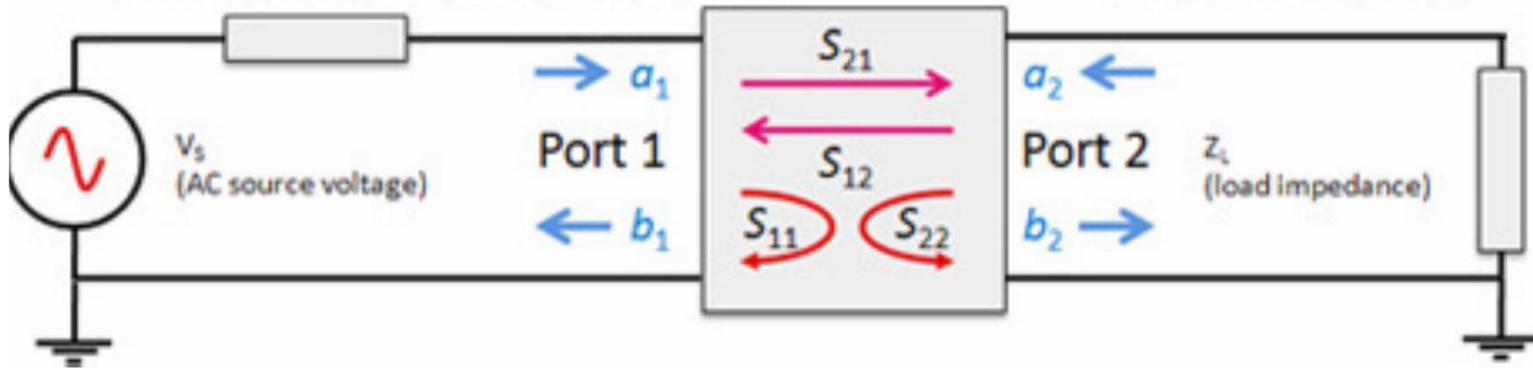

E4B08 (C)

Which of the following is a characteristic of a good DC voltmeter? **High impedance input**

A voltmeter with high input impedance will not load the circuit being measured and will therefore provide a more accurate representation of circuit performance.

E4B09 (D)

What is indicated if the current reading on an RF ammeter placed in series with the antenna feed line of a transmitter increases as the transmitter is tuned to resonance? **There is more power going into the antenna**

E4B10 (B)

Which of the following describes a method to measure intermodulation distortion in an SSB transmitter? **Modulate the transmitter with two non-harmonically related audio frequencies and observe the RF output with a spectrum analyzer**

E4B11 (D)

How should an antenna analyzer be connected when measuring antenna resonance and feed point impedance? **Connect the antenna feed line directly to the analyzer's connector**

When measuring antennas with an antenna analyzer make sure you short the antenna feedline center conductor to the ground side of the antenna connector to prevent static charges from damaging the antenna analyzer.

E4B12 (A)

What is the significance of voltmeter sensitivity expressed in ohms per volt? **The full scale reading of the voltmeter multiplied by its ohms per volt rating will indicate the input impedance of the voltmeter**

A 20,000 ohm per volt voltmeter will present a 200k Ohm circuit load on the measured circuit when on its 10 volt Full scale range.

E4B13 (C)

Which S parameter is equivalent to forward gain? **S21**

E4B14 (B)

What happens if a dip meter is too tightly coupled to a tuned circuit being checked? **A less accurate reading result**

Because the close proximity of the grid dip meter coil to the circuit being measured will change the inductance in the circuit being measured and create a resonant frequency error.



E4B15 (C)

Which of the following can be used as a relative measurement of the Q for a series-tuned circuit?

The bandwidth of the circuit's frequency response

E4B16 (A)

Which S parameter represents return loss or SWR?

S11

E4B17 (B)

What three test loads are used to calibrate a standard RF vector network analyzer? **Short circuit, open circuit, and 50 ohms**

Element 4 Sub-Element C

E4C01 (D)

What is an effect of excessive phase noise in the local oscillator section of a receiver? **It can cause strong signals on nearby frequencies to interfere with reception of weak signals**

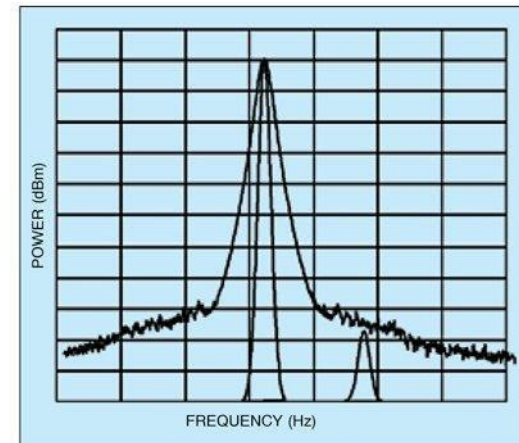
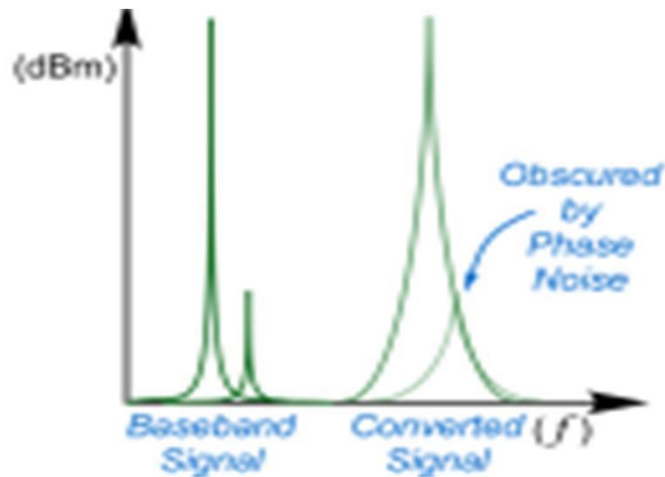

Fig. 2: Because of high FM noise, noise level close to the carrier is very high, masking the low-level signal

E4C02 (A)

Which of the following portions of a receiver can be effective in eliminating image signal interference?

A front-end filter or pre-selector



E4C03 (C)

What is the term for the blocking of one FM phone signal by another, stronger FM phone signal? **Capture effect**

E4C04 (D)

How is the noise figure of a receiver defined? **The ratio in dB of the noise added by the receiver or amplifier to the theoretical minimum noise**

Noise figure (NF) is a measure of degradation of the signal-to-noise ratio (SNR), caused by components in a radio frequency (RF) signal chain. It is a number by which the performance of an amplifier or a radio receiver can be specified, with lower values indicating better performance.

E4C05 (B)

What does a value of -174 dBm / Hz represent with regard to the noise floor of a receiver? **The theoretical noise at the input of a perfect receiver at room temperature**

E4C06 (D)

A CW receiver with the AGC off has an equivalent input noise power density of -174 dBm/Hz. What would be the level of an unmodulated carrier input to this receiver that would yield an audio output SNR of 0 dB in a 400 Hz noise bandwidth? **-148 dBm**

The level with a 400 Hz receiver bandwidth is the dB differences between a one hertz bandwidth and the 400 Hz bandwidth:

$dB=10 \log 400/1$ or 26 dB higher than the noise in a 1 HZ bandwidth or $-174 +26$ or -148 dBm .

E4C07 (B)

What does the MDS of a receiver represent? **The minimum discernible signal**

The smallest signal you can pick out of the background thermal noise.

E4C08 (C)

An SDR receiver is overloaded when input signals exceed what level? **The maximum count value of the analog-to-digital converter**

E4C09 (C)

Which of the following choices is a good reason for selecting a high frequency for the design of the IF in a conventional HF or VHF communications receiver?

Easier for front-end circuitry to eliminate image responses

E4C10 (B)

Which of the following is a desirable amount of selectivity for an amateur RTTY HF receiver? **300 Hz**

E4C11 (B)

Which of the following is a desirable amount of selectivity for an amateur SSB phone receiver? **2.4 kHz**

E4C12 (D)

What is an undesirable effect of using too wide a filter bandwidth in the IF section of a receiver? **Undesired signals may be heard**

And the signal to noise of the received signal has a lower signal to noise ratio

E4C13 (C)

How does a narrow-band roofing filter affect receiver performance? **It improves dynamic range by attenuating strong signals near the receive frequency**

A roofing filter is a filter inserted just before the IF amplifier stages or just after the first IF amplifier stage to reduce IF amplifier overloading from undesired signals.

E4C14 (D)

What transmit frequency might generate an image response signal in a receiver tuned to 14.300 MHz and which uses a 455 kHz IF frequency? **15.210 MHz**

The Local Oscillator signal would be 455 KHz higher than the receive frequency, or 13,755 Mhz. A signal 455 KHz above this LO Frequency would also produce a 455 KHz if output or $13.755\text{MHz} + .455\text{KHz}$ or 15.210 MHz

E4C15 (D)

What is usually the primary source of noise that is heard from an HF receiver with an antenna connected?

Atmospheric noise

E4C16 (A)

Which of the following is caused by missing codes in an SDR receiver's analog-to-digital converter?

Distortion

E4C17 (D)

Which of the following has the largest effect on an SDR receiver's linearity? **Analog-to-digital converter**
sample width in bits

Element 4 Sub-Element D

E4D01 (A)

What is meant by the blocking dynamic range of a receiver? **The difference in dB between the noise floor and the level of an incoming signal which will cause 1 dB of gain compression**

E4D02 (A)

Which of the following describes two problems caused by poor dynamic range in a communications receiver? **Cross-modulation of the desired signal and desensitization from strong adjacent signals**

E4D03 (B)

How can intermodulation interference between two repeaters occur? **When the repeaters are in close proximity and the signals mix in the final amplifier of one or both transmitters**

This is why circulators are recommended in repeater antenna lines. Circulators block signals from getting back to the transmitter circuits from the antenna.

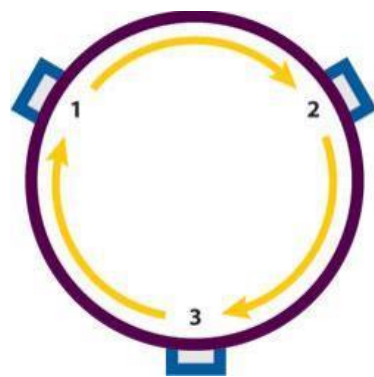

E4D04 (B)

Which of the following may reduce or eliminate intermodulation interference in a repeater caused by another transmitter operating in close proximity? **A properly terminated circulator at the output of the transmitter**

E4D05 (A)

What transmitter frequencies would cause an intermodulation-product signal in a receiver tuned to 146.70 MHz when a nearby station transmits on 146.52 MHz? **146.34 MHz and 146.61 MHz**

First intermodulation product is: $I_{mod} = 2F_1 - f_2$

$$146.70 = 2(146.52) - f_2 \quad \text{or} \quad 146.70 - f_2 \quad \text{or} \quad 146.7 - 293.04 = -$$

~~Second intermodulation product is: $F_1 - 2f_2$~~

$$146.70 = 146.52 - 2 f_2 \quad \text{or} \quad 146.70 + 145.52 = 2 f_2 \quad \text{or}$$

$$293.22 = 2 f_2 \quad \text{or} \quad f_2 = 146.61 \text{ MHz}$$

E4D06 (D)

What is the term for unwanted signals generated by the mixing of two or more signals? **Intermodulation interference**

Frequently referred to as intermodulation products

E4D07 (D)

Which describes the most significant effect of an off-frequency signal when it is causing cross-modulation interference to a desired signal? **The off-frequency unwanted signal is heard in addition to the desired signal**

E4D08 (C)

What causes intermodulation in an electronic circuit?

Nonlinear circuits or devices

This can be a diode or a rusty joint on an antenna or antenna support structure or any other poor connection acting like a mixer diode.

E4D09 (C)

What is the purpose of the preselector in a communications receiver? **To increase rejection of unwanted signals**

E4D10 (C)

What does a third-order intercept level of 40 dBm mean with respect to receiver performance?

A pair of 40 dBm signals will theoretically generate a third-order intermodulation product with the same level as the input signals

A pair of signals as they are increased together will produce a third order intercept products. The third order signal increases at faster rate (3:1) than when the two test signals are increased. When the third order signal rises to the level of the test signals this is considered the third order intercept point and is expressed in dBm.

E4D11 (A)

Why are third-order intermodulation products created within a receiver of particular interest compared to other products? **The third-order product of two signals which are in the band of interest is also likely to be within the band**

E4D12 (A)

What is the term for the reduction in receiver sensitivity caused by a strong signal near the received frequency? **Desensitization**

Desensitization is the loss of sensitivity of a receiver caused by a strong nearby signal(s) that overload the receiver input.

E4D13 (B)

Which of the following can cause receiver desensitization? **Strong adjacent channel signals**

Adjacent-channel interference (ACI) is interference caused by extraneous power from a signal in an adjacent channel.

E4D14 (A)

Which of the following is a way to reduce the likelihood of receiver desensitization? **Decrease the RF**

bandwidth of the receiver

This means at the RF input stage not the IF which is where Band Width reduction filters are normally placed. This can be accomplished with an RF Preselector.

Element 4 Sub-Element E

E4E01 (A)

Which of the following types of receiver noise can often be reduced by use of a receiver noise blanker?

ignition noise

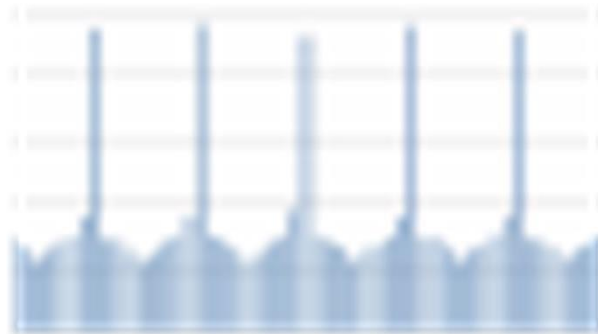

E4E02 (D)

Which of the following types of receiver noise can often be reduced with a DSP noise filter?

A. Broadband white noise

B. Ignition noise

C. Power line noise

D. All of these choices are correct

DSP is Digital Signal Processing.

E4E03 (B)

Which of the following signals might a receiver noise blanker be able to remove from desired signals?

Signals which appear across a wide bandwidth

A noise blanker is a device that detects pulses and blocks the signal during the time of each noise pulse.

E4E04 (D)

How can conducted and radiated noise caused by an automobile alternator be suppressed? **By connecting the radio's power leads directly to the battery and by installing coaxial capacitors in line with the alternator leads**

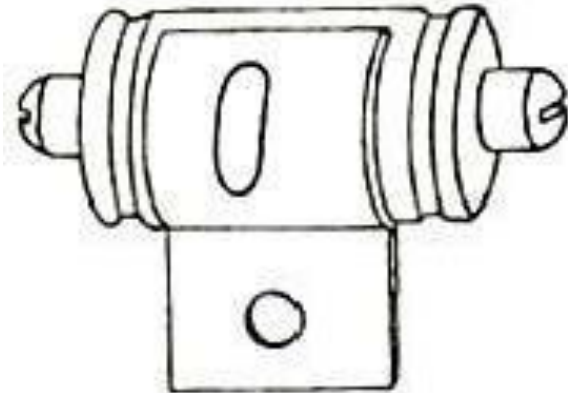

E4E05 (B)

How can noise from an electric motor be suppressed?

By installing a brute-force AC-line filter in series with the motor leads

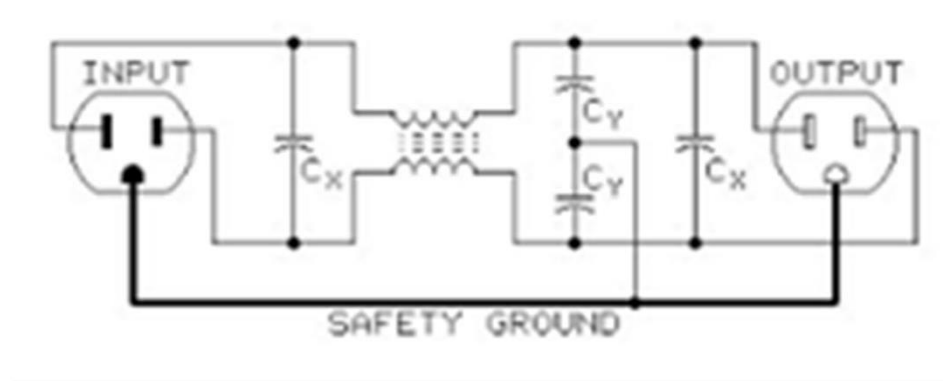

E4E06 (B)

What is a major cause of atmospheric static?

Thunderstorms

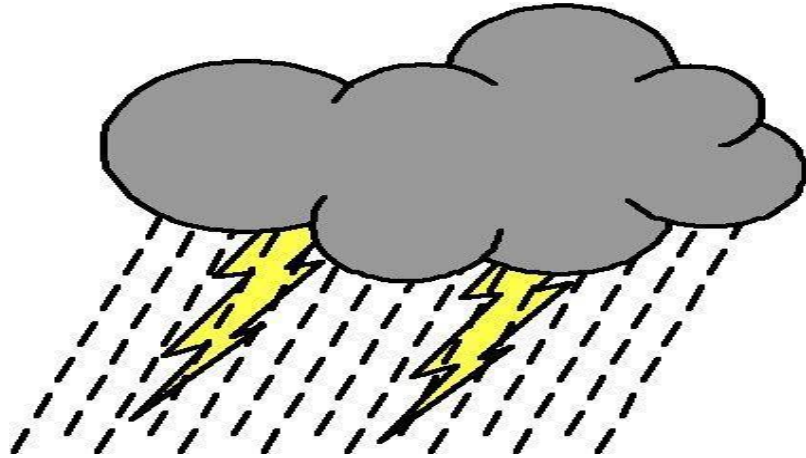

E4E07 (C)

How can you determine if line noise interference is being generated within your home? **By turning off the AC power line main circuit breaker and listening on a battery operated radio**

E4E08 (A)

What type of signal is picked up by electrical wiring near a radio antenna? **A common-mode signal at the frequency of the radio transmitter**

E4E09 (C)

What undesirable effect can occur when using an IF noise blanker? **Nearby signals may appear to be excessively wide even if they meet emission standards**

E4E10 (D)

What is a common characteristic of interference caused by a touch controlled electrical device?

- A. The interfering signal sounds like AC hum on an AM receiver or a carrier modulated by 60 Hz hum on a SSB or CW receiver**
- B. The interfering signal may drift slowly across the HF spectrum**
- C. The interfering signal can be several kHz in width and usually repeats at regular intervals across a HF band**
- D. All of these choices are correct**

E4E11 (B)

Which is the most likely cause if you are hearing combinations of local AM broadcast signals within one or more of the MF or HF ham bands? **Nearby corroded metal joints are mixing and re-radiating the broadcast signals**

E4E12 (A)

What is one disadvantage of using some types of automatic DSP notch-filters when attempting to copy CW signals? **A DSP filter can remove the desired signal at the same time as it removes interfering signals**

E4E13 (D)

What might be the cause of a loud roaring or buzzing AC line interference that comes and goes at intervals?

- A. Arcing contacts in a thermostatically controlled device**
- B. A defective doorbell or doorbell transformer inside a nearby residence**
- C. A malfunctioning illuminated advertising display**
- D. All of these choices are correct**

E4E14 (C)

What is one type of electrical interference that might be caused by the operation of a nearby personal computer? **The appearance of unstable modulated or unmodulated signals at specific frequencies**

E4E15 (B)

Which of the following can cause shielded cables to radiate or receive interference? **Common mode currents on the shield and conductors**

E4E16 (B)

What current flows equally on all conductors of an unshielded multi-conductor cable? **Common-mode current**

Common mode currents can be reduced with shielded cables or by twisting the wires or with toroids.

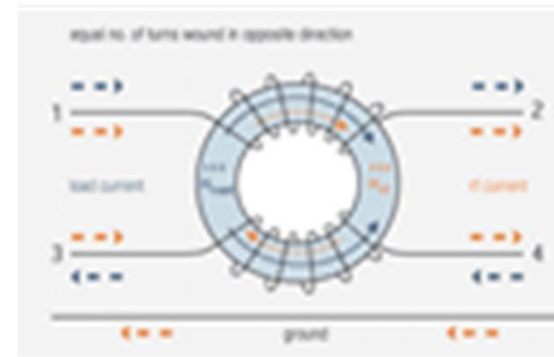
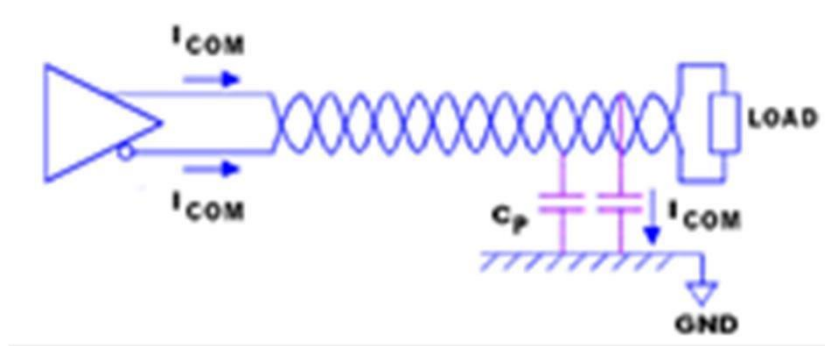

ELEMENT E5
ELECTRICAL PRINCIPLES
[4 Exam Questions - 4 Groups]

Element 5 Sub-Element A

E5A01 (A)

What can cause the voltage across reactances in series to be larger than the voltage applied to them?

Resonance

E5A02 (C)

What is resonance in an electrical circuit? **The frequency at which the capacitive reactance equals the inductive reactance**

In this condition the current flowing in the circuit is limited only by the circuit resistance.

E5A03 (D)

What is the magnitude of the impedance of a series RLC circuit at resonance? **Approximately equal to circuit resistance**

E5A04 (A)

What is the magnitude of the impedance of a circuit with a resistor, an inductor and a capacitor all in parallel, at resonance? **Approximately equal to circuit resistance**

5A05 (B)

What is the magnitude of the current at the input of a series RLC circuit as the frequency goes through resonance? **Maximum**

Because at resonance the current flowing in the circuit is limited only by the circuit resistance.

E5A06 (B)

What is the magnitude of the circulating current within the components of a parallel LC circuit at resonance?
It is at a maximum

E5A07 (A)

What is the magnitude of the current at the input of a parallel RLC circuit at resonance? **Minimum**

At resonance the current from the inductor charges the capacitor on half of the cycle and the capacitor charges the inductor on the other half cycle.

E5A08 (C)

What is the phase relationship between the current through and the voltage across a series resonant circuit at resonance? **The voltage and current are in phase**

E5A09 (C)

How is the Q of an RLC parallel resonant circuit calculated?
Resistance divided by the reactance of either the inductance or capacitance

E5A10 (A)

How is the Q of an RLC series resonant circuit calculated? **Reactance of either the inductance or capacitance divided by the resistance**

$$Q = X_L / R \quad \text{or} \quad Q = X_C / R$$

Examples:

For a circuit with a capacitive reactance of 25 ohms and a resistance of .5 ohms the Q would be 50

$$Q = 25 \div 0.5 \quad \text{or} \quad 50$$

For a circuit with 70 ohms of inductive reactance and a resistance of 2 ohms the Q would be 35

$$Q = 70 \div 2 \quad \text{or} \quad Q = 35$$

E5A11 (C)

What is the half-power bandwidth of a parallel resonant circuit that has a resonant frequency of 7.1 MHz and a Q of 150? **47.3 kHz**

$$BW = \text{Frequency} / Q \text{ or } 7100 \text{ KHz} / 150 \text{ or } 47.3 \text{ KHz}$$

E5A12 (C)

What is the half-power bandwidth of a parallel resonant circuit that has a resonant frequency of 3.7 MHz and a Q of 118? **31.4 kHz**

$$BW = \text{Frequency} / Q \text{ or } 3700 \text{ KHz} / 118 \text{ or } 31.356$$

E5A13 (C)

What is an effect of increasing Q in a resonant circuit?

Internal voltages and circulating currents increase

E5A14 (C)

What is the resonant frequency of a series RLC circuit if R is 22 ohms, L is 50 microhenrys and C is 40 picofarads? **3.56 MHz**

$F(\text{resonance in MHz}) = 1,000 / (2\pi (L \times C))$ where Inductance is in micro-henries and capacitance is in picofarads:

$$F(\text{resonance}) = 1,000 / (2 (L \times C)) \text{ or}$$

$$F(\text{resonance}) = 1,000 / (6.28 (50 \times 40)) \text{ or } 3.56 \text{ MHz}$$

E5A15 (A)

Which of the following can increase Q for inductors and capacitors? **Lower losses**

E5A16 (D)

What is the resonant frequency of a parallel RLC circuit if R is 33 ohms, L is 50 microhenrys and C is 10 picofarads? **7.12 MHz**

$F(\text{resonance}) = 1,000 / (2 \sqrt{L \times C})$ or $1,000 / (6.28 \sqrt{50 \times 10})$ or 7.121 MHz

E5A17 (A)

What is the result of increasing the Q of an impedance-matching circuit? **Matching bandwidth is decreased**

RC Time Constant Tutorial

When a voltage is applied to a capacitor through a resistance (all circuits have resistance) it takes time for the voltage across the capacitor to reach the applied voltage. At the instant the voltage is applied the current in the circuit is at a maximum limited only by the circuit resistance. As time passes the voltage across the capacitor rises and the current decreases until the capacitor charge reaches the applied voltage at which point the current goes to zero.

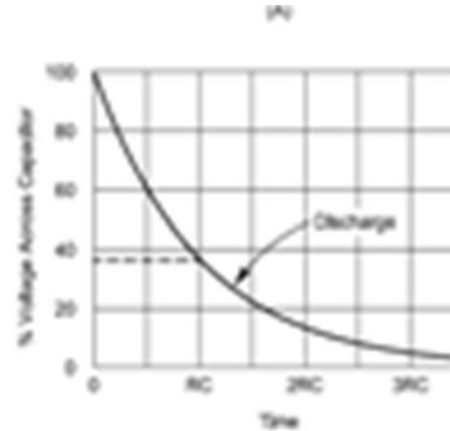
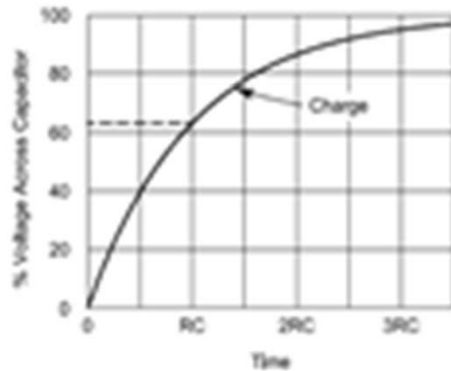

The voltage across the capacitor will rise to 63.2 % of the applied voltage in one time constant. The time constant in seconds is calculated by multiplying the resistance in megohms by the capacitance in microfarads.

***Time Constant = $R(\text{ohms}) \times C(\text{farads})$
or in terms of more common values :
 $TC = R(\text{megohms}) \times C(\text{microfarads})$***

For example, 100 volts applied to 1 μ F capacitor with a series one megohm resistor will charge to 63.2 volts in one second. Remember that $TC = R$ (megohms) \times C (microfarads) or $TC = 1 \times 1$ or 1 second and the charge after 1 time constant will be 63.2% of the applied 100 volts, or 63.2 volts

Time Constants	Charge % of applied voltage	Discharge % of starting voltage
1	63.2%	36.8%
2	86.5%	13.5 %
3	95.0%	5%
4	98.2%	1.8%
5	99.3%	.7%

Element 5 Sub-Element B

E5B01 (B)

What is the term for the time required for the capacitor in an RC circuit to be charged to 63.2% of the applied voltage? **One time constant**

Time Constants	Charge % of applied voltage	Discharge % of starting voltage
1	63.2%	36.8%
2	86.5%	13.5 %
3	95.0%	5%
4	98.2%	1.8%
5	99.3%	.7%

E5B02 (D)

What is the term for the time it takes for a charged capacitor in an RC circuit to discharge to 36.8% of its initial voltage? **One time constant**

One time constant discharge would be 100% - 63.2% or 36.8%

E5B03 (B)

What happens to the phase angle of a reactance when it is converted to a susceptance? **The sign is reversed**

Therefore the phase angle for inductive admittance will be negative and the phase angle for capacitive admittance will be positive

E5B04 (D)

What is the time constant of a circuit having two 220 microfarad capacitors and two 1 megohm resistors, all in parallel? **220 seconds**

TC (seconds) = R (megohms) x C (microfarads) or

*TC = (1/2) x (220 x 2) or TC = 0.5 x 440 or TC = 220
seconds*

Remember that capacitors in parallel add and resistors of equal value in parallel are equal to one resistor divided by the number of resistors.

E5B05 (D)

What happens to the magnitude of a reactance when it is converted to a susceptance? **The magnitude of the susceptance is the reciprocal of the magnitude of the reactance**

E5B06 (C)

What is susceptance? **The inverse of reactance**

$$Y \text{ (admittance)} = 1/Z$$

$$G \text{ (conductance)} = 1/R$$

$$B_L \text{ (Inductive Susceptance)} = 1/(2\pi FL)$$

$$B_C \text{ (Capacitive Susceptance)} = 2\pi FC$$

Trigonometry Tutorial

For a number of problems associated with electronics involving series circuits of resistance and reactance in the Extra class Exam you will need a basic understanding of trigonometry. The problems center on a right triangle (that is a triangle that has one angle that is 90° and the sum of the remaining two angles is equal to 90°). Using trigonometric functions if we know two sides, or an angle (other than the 90° angle) and one side of the triangle we can calculate the remaining angles and dimensions.

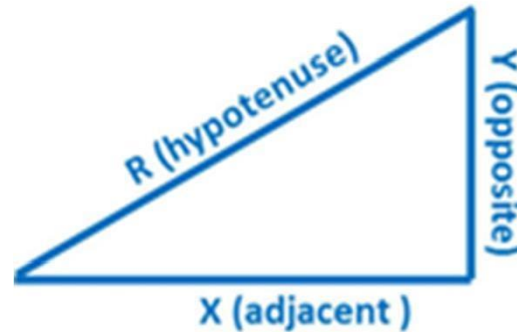

The sides of the triangle are given names from the rectangular coordinate system with the horizontal side called X (also called the Adjacent side) and the vertical side is called Y (also called the opposite side) and the side connecting the X and Y sides is called the Hypotenuse called R in this example. If two of the three sides are known the third side can be found using the following equation:

$$R_{(\text{Hypotenuse})} = \sqrt{X^2 + Y^2}$$

Examples:

If X=3 and Y=4 then R=5

$$H = \sqrt{3^2 + 4^2} \text{ or } H = \sqrt{25} \text{ or Hypotenuse} = 5$$

If X=5 and Y=10 then R=11.18

$$H = \sqrt{5^2 + 10^2} \text{ or } H = \sqrt{125} \text{ or Hypotenuse} = 11.18$$

If X=153 and Y=52 then R=161.6

$$H = \sqrt{153^2 + 52^2} \text{ or } H = \sqrt{26,113} \text{ or Hypotenuse} = 161.6$$

If X=50 and Y=100 then R=111.80

$$H = \sqrt{50^2 + 100^2} \text{ or } H = \sqrt{12,500} \text{ or Hypotenuse} = 111.8$$

There are three trigonometric functions that can be used to calculate the angle θ between X and R and between Y and R . They are Sine, Cosine and Tangent to solve for the angle between the X side and the R side.

Sine of $\theta = Y / R$

Cosine of $\theta = X / R$

Tangent of $\theta = Y / X$

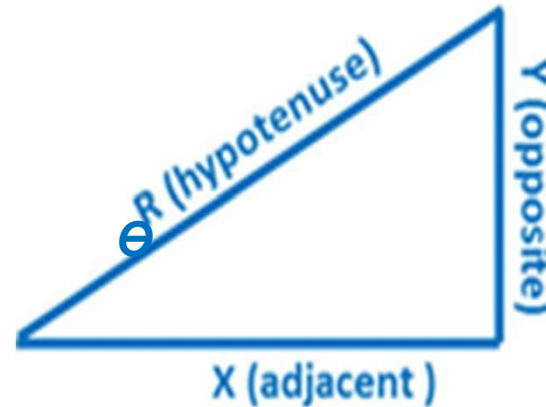

Example 1:

To find the angle, θ for a triangle with side X value of 3 and a side Y value of 6:

Tangent of $\theta = 6 / 3$ or 2.00. To find the angle enter 2 into your calculator and press the Arc Tan key which will show you the angle represented by the tangent value, in this case 2.00. The Arc Tan of 2 is 63.43° .

Example 2:

To find the angle, Θ for a triangle with a side X value of 3 and a side Y value of 4:

Tangent of $\Theta = 4 / 3$ or 1.333 To find the angle enter 1.333 into your calculator and press the Arc Tan(or Tan^{-1} on some calculators) key which will show you 53.13°

Example 3:

To find the angle, Θ for a triangle with a side X value of 12 and a side Y value of 12

Tangent of $\Theta = 12/12$ or 1 To find the angle enter 1 into your calculator and press the Arc Tan key which will show you 45.0°

Inductive and Capacitive Reactance Tutorial

Reactance (AC resistance of capacitors and inductors)

Capacitors and inductors exhibit a resistance to current flow much like a resistor but with values that change with the frequency of the applied circuit.

The AC resistance of a capacitor is called capacitive reactance (X_c) and is calculated using the formula:

$$X_c = 1 / (2\pi \times F \times C) \text{ with } C \text{ in } \mu\text{F} \text{ and } F \text{ in MHz}$$

Capacitive reactance Examples:

1. Find the capacitive reactance of a 1 μ f capacitor at 200 Hz

$$X_c = 1/(2\pi \times F \times C) \text{ or } X_c = 1/(6.28 \times .0002 \times 1) \text{ or } X_c = 796 \Omega$$

2. Find the Capacitive reactance of a 10 PF capacitor at 7 MHz

$$X_c = 1/(2\pi \times F \times C) \text{ or } X_c = 1/(6.28 \times 7.0 \times 10^{-6}) \text{ or } X_c = 2,275 \Omega$$

The AC resistance of an Inductor is called Inductive reactance (X_L) and is calculated using the formula: $X_L = 2\pi \times F \times L$ with L in μH and F in MHz

Inductive Reactance Examples:

1. Find the inductive reactance of a 1 μH inductor at 100 MHz

$$X_L = 2\pi \times F \times L \quad \text{or} \quad X_L = 6.28 \times 100 \times 1 \quad \text{or} \quad X_L = 628 \Omega$$

2. Find the inductive reactance of a 100 μH inductor at 7 MHz

$$X_L = 2\pi \times F \times L \quad \text{or} \quad X_L = 6.28 \times 7 \times 100 \quad \text{or} \quad X_L = 4,398 \Omega$$

Circuit Impedance

The term Impedance refers to the equivalent circuit resistance in ohms for a circuit consisting of resistance and capacitive reactance and / or inductive reactance. To solve these problems for series circuits we use a rectangular coordinate graph and basic algebra and trigonometry. When working with complex circuits containing resistance and reactance, the reactive components are shown with a lower case j prefix. Inductive reactance is shown with a +j prefix and capacitive reactance with a -j prefix.

Rectangular Coordinate System

When solving problems involving impedance and phase angle of AC series circuits we show the circuit element values in a rectangular

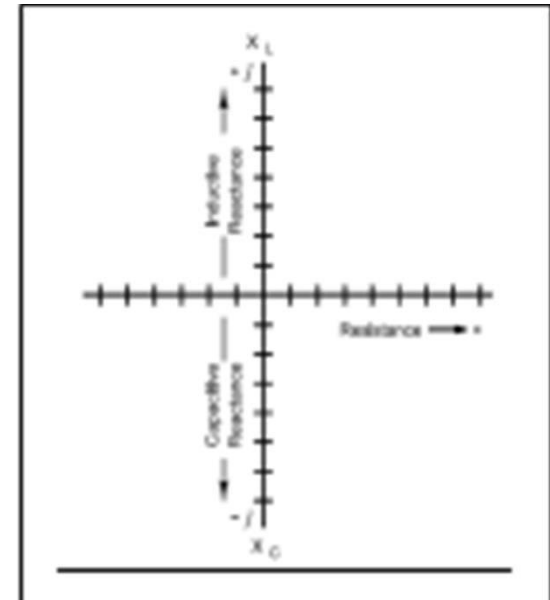

format. The rectangular format consists of a horizontal line intersected at 90° by a vertical line. Values on the horizontal or X axis are positive to the right of the vertical line and negative to the left. Values on the vertical or Y axis are positive above the X axis and Negative below the X axis.

E5B07 (C)

What is the phase angle between the voltage across and the current through a series RLC circuit if XC is 500 ohms, R is 1 kilohm, and XL is 250 ohms? **14.0 degrees with the voltage lagging the current**

*Tangent of $\theta = Y \div X$ or Tangent of $\theta = -250 \div 1000$ or
Arc Tangent of $\theta = -0.25$ or $\theta = -14.04^\circ$*

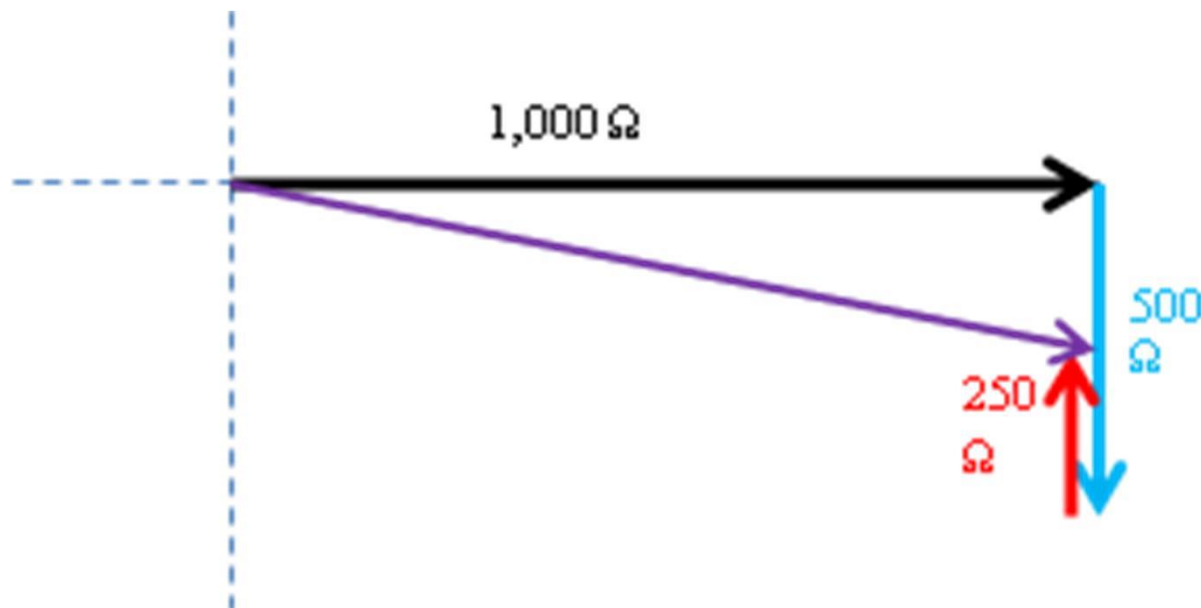

E5B08 (A)

What is the phase angle between the voltage across and the current through a series RLC circuit if XC is 100 ohms, R is 100 ohms, and XL is 75 ohms? **14 degrees with the voltage lagging the current**

*Tangent of $\theta = Y \div X$ or Tangent of $\theta = -100 + 75 \div 100$
or arc Tangent of $\theta = -0.25$ or $\theta = -14.04^\circ$*

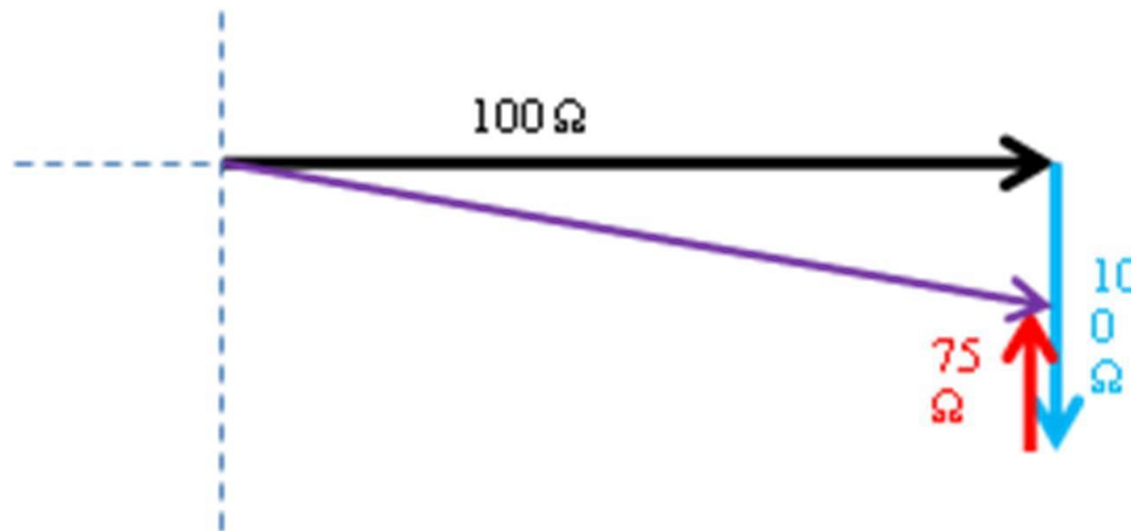

E5B09 (D)

What is the relationship between the current through a capacitor and the voltage across a capacitor?

Current leads voltage by 90 degrees

E5B10 (A)

What is the relationship between the current through an inductor and the voltage across an inductor?

Voltage leads current by 90 degrees

E5B11 (B)

What is the phase angle between the voltage across and the current through a series RLC circuit if X_C is 25 ohms, R is 100 ohms, and X_L is 50 ohms? **14 degrees with the voltage leading the current**

Tangent of $\theta = Y \div X$ or Tangent of $\theta = (50-25) \div 100$ or Tangent of $\theta = .25$ or $\theta = +14.04^\circ$

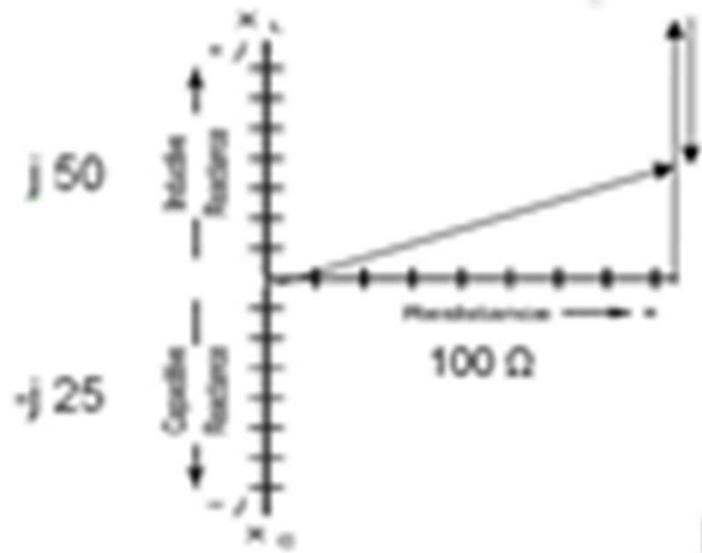

E5B12 (A)

What is admittance? **The inverse of impedance**

The admittance of 50 Ω = $1 \div 50$ or 0.02.

The admittance of 2 Ω = $1 \div 2$ or 0.5

E5B13 (D)

What letter is commonly used to represent susceptance? **B**

B_L (Inductive Susceptance) = $1 \div (2\pi FL)$

B_C (Capacitive Susceptance) = $2\pi FC$

Element 5 Sub-Element C

E5C01 (A)

Which of the following represents a capacitive reactance in rectangular notation? **- jX**

E5C02 (C)

How are impedances described in polar coordinates?

By phase angle and amplitude

Examples:

47Ω, 30°

35Ω, - 45°

E5C03 (C)

Which of the following represents an inductive reactance in polar coordinates? **A positive phase angle**

E5C04 (D)

Which of the following represents a capacitive reactance in polar coordinates? **A negative phase angle**

E5C05 (C)

What is the name of the diagram used to show the phase relationship between impedances at a given frequency? **Phasor diagram**

E5C06 (B)

What does the impedance $50 -j25$ represent? **50 ohms resistance in series with 25 ohms of capacitive reactance**

E5C07 (B)

What is a vector? **A quantity with both magnitude and an angular component**



E5C08 (D)

What coordinate system is often used to display the phase angle of a circuit containing resistance, inductive and/or capacitive reactance? **Polar coordinates**

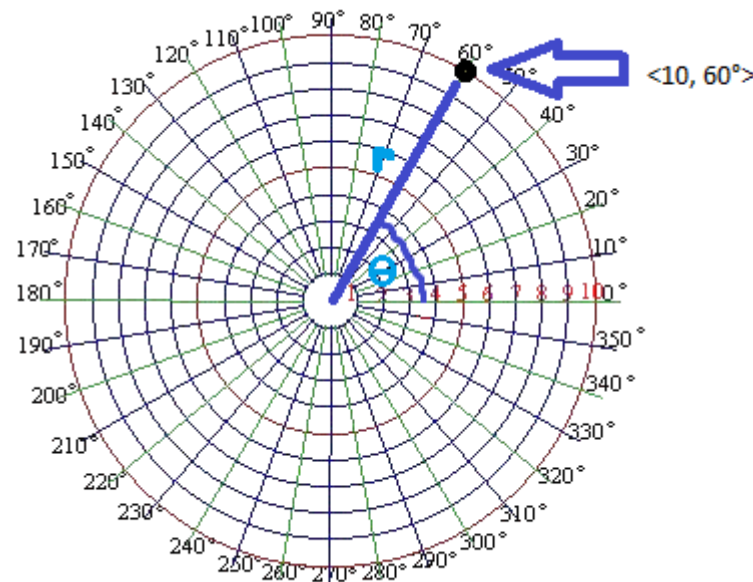

E5C09 (A)

When using rectangular coordinates to graph the impedance of a circuit, what does the horizontal axis represent? **Resistive component**

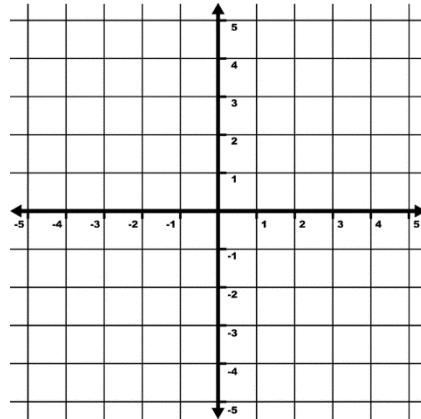

E5C10 (B)

When using rectangular coordinates to graph the impedance of a circuit, what does the vertical axis represent? **Reactive component**

E5C10 (B)

When using rectangular coordinates to graph the impedance of a circuit, what does the vertical axis represent? **Reactive component**

E5C11 (C)

What do the two numbers that are used to define a point on a graph using rectangular coordinates represent? **The coordinate values along the horizontal and vertical axes**

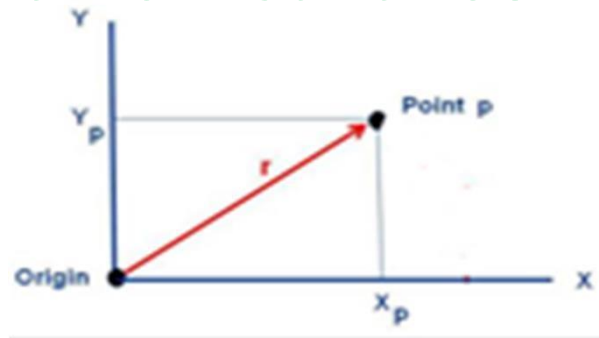

E5C12 (D)

If you plot the impedance of a circuit using the rectangular coordinate system and find the impedance point falls on the right side of the graph on the horizontal axis, what do you know about the circuit?

It is equivalent to a pure resistance

E5C13 (D)

What coordinate system is often used to display the resistive, inductive, and/or capacitive reactance components of impedance?

Rectangular coordinates

E5C14 (B)

Which point on Figure E5-2 best represents the impedance of a series circuit consisting of a 400 ohm resistor and a 38 picofarad capacitor at 14 MHz?

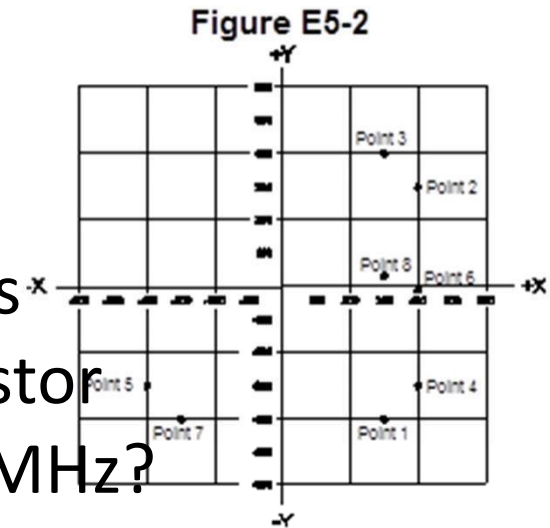

Point 4

$$X_c = 2 / 2\pi FC \text{ or } X_c = 1 / (6.28 \times 14 \times 0.000038) \text{ or}$$

$$X_c = -299 \Omega$$

In rectangular coordinates 400Ω (X Axis) and -299 Ω (Y axis)

E5C15 (B)

Which point in Figure E5-2 best represents the impedance of a series circuit consisting of a 300 ohm resistor and an 18 microhenry inductor at 3.505 MHz?

Point 3

$$XL = 2\pi FL \text{ or } XL = 6.28 \times 3.505 \times 18 \text{ or } XL = +396.4 \Omega$$

In rectangular coordinates 300Ω (X Axis) and +396Ω (Y axis)

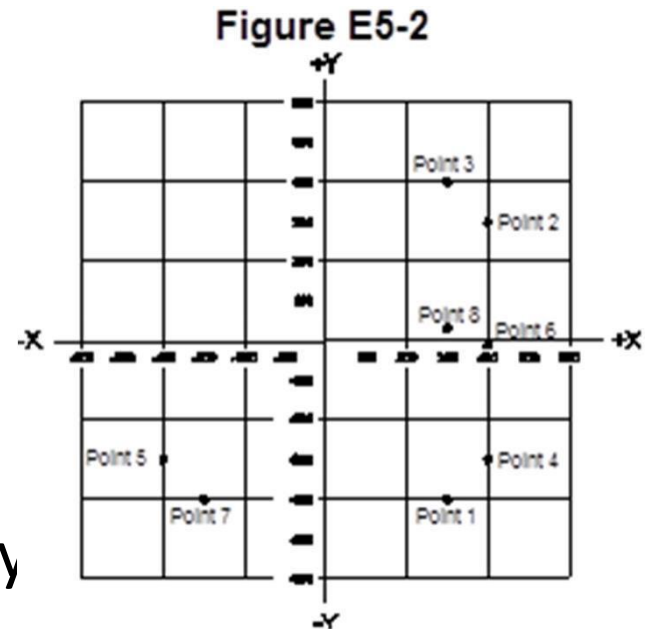

E5C16 (A)

Which point on Figure E5-2 best represents the impedance of a series circuit consisting of a 300 ohm resistor and a 19 picofarad capacitor at 21.200 MHz?

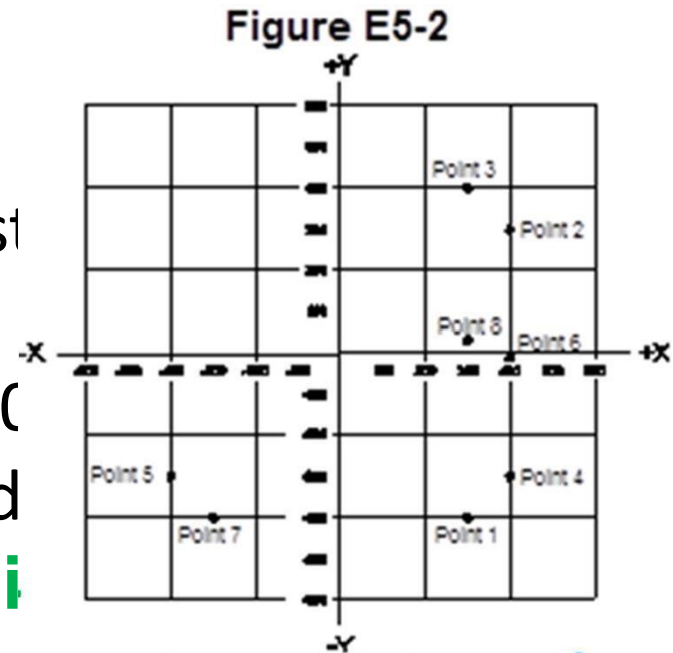

$$X_c = 2 / 2\pi FC \text{ or } X_c = 1 / (6.28 \times 21.2 \times 0.000019)$$
$$\text{or } X_c = -395 \Omega$$

In rectangular coordinates 300Ω (X Axis) and -395 Ω (Y axis)

E5C17 (D)

Which point on Figure E5-2 best represents the impedance of a series circuit consisting of 300 ohm resistor, a 0.64 microhenry inductor and an 85 picofarad capacitor at 24.900 MHz

Figure E5-2

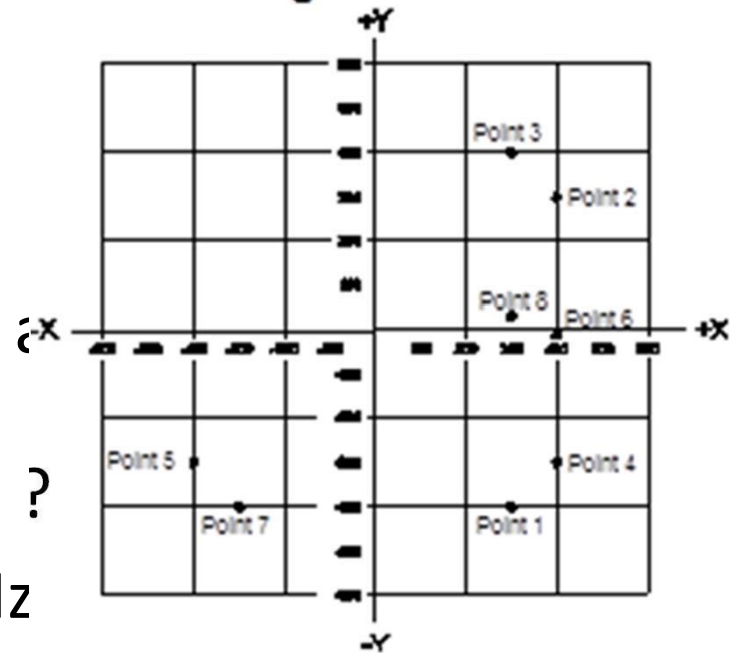

Point 8

Total Reactance $R_t = (\text{Inductive reactance}) - (\text{Capacitive reactance})$

$$R_t = (2\pi FL) - (1/2\pi FC) \quad \text{or} \quad 6.28 \times 24.9 \times .64) - (1/6.28 \times 29.4 \times 0.000085) \quad \text{or} \quad 100 - 75.2 \quad \text{or} \quad +24.8 \Omega$$

In rectangular coordinates 300Ω (X Axis) and +24.8Ω (Y axis)

Element 5 Sub-Element D

E5D01 (A)

What is the result of skin effect? **As frequency increases, RF current flows in a thinner layer of the conductor, closer to the surface**

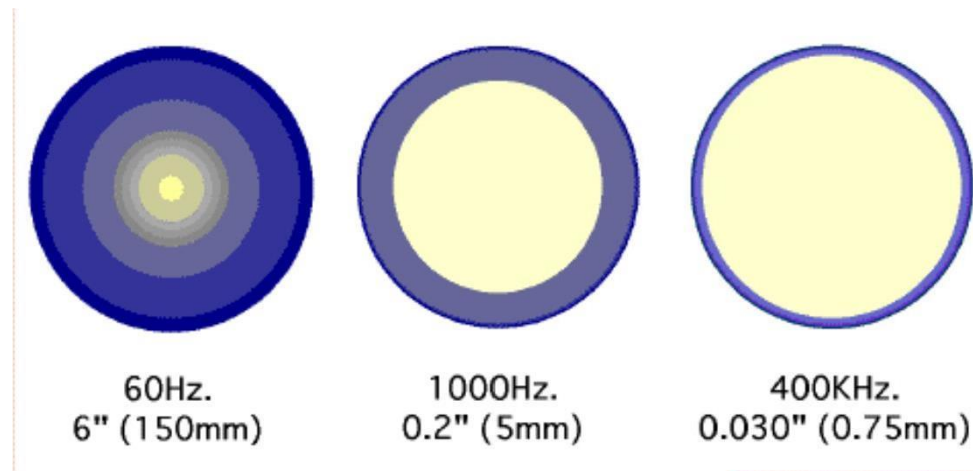

E5D02 (B)

Why is it important to keep lead lengths short for components used in circuits for VHF and above?

To avoid unwanted inductive reactance

E5D03 (D)

What is microstrip? **Precision printed circuit conductors above a ground plane that provide constant impedance interconnects at microwave frequencies**

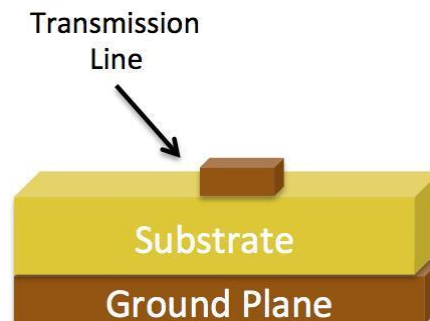

E5D04 (B)

Why are short connections necessary at microwave frequencies? **To reduce phase shift along the connection**

E5D05 (A)

Which parasitic characteristic increases with conductor length? **Inductance**

E5D06 (D)

In what direction is the magnetic field oriented about a conductor in relation to the direction of electron flow?

In a direction determined by the left-hand rule

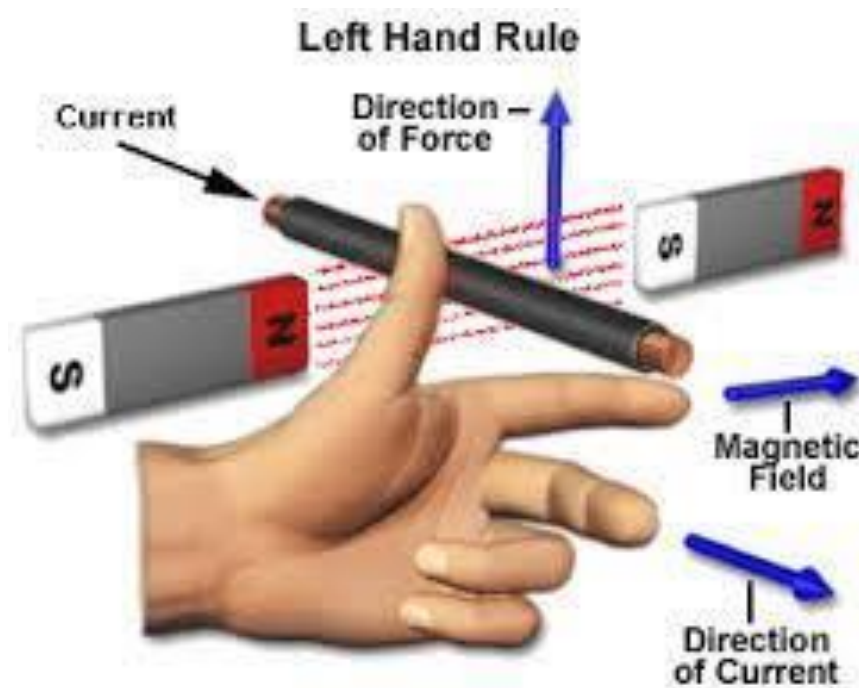

E5D07 (D)

What determines the strength of the magnetic field around a conductor? **The amount of current flowing through the conductor**

E5D08 (B)

What type of energy is stored in an electromagnetic or electrostatic field? **Potential energy**

E5D09 (B)

What happens to reactive power in an AC circuit that has both ideal inductors and ideal capacitors? **It is repeatedly exchanged between the associated magnetic and electric fields, but is not dissipated**

Power Factor Tutorial

The power factor of an AC electrical power system is defined as the ratio of the real power flowing to the load to the apparent power in the circuit, and is a dimensionless number in the closed interval of -1 to 1. A power factor of less than one means that the voltage and current waveforms are not in phase, reducing the instantaneous product of the two waveforms ($V \times I$). Real power is the capacity of the circuit for performing work in a particular time. Apparent power is the product of the current and voltage of the circuit. Due to energy stored in the load and returned to the source, or due to a non-linear load that distorts the wave shape of the current drawn from the source, the apparent power will be greater than the real power.

A negative power factor occurs when the device (which is normally the load) generates power, which then flows back towards the source, which is normally considered the generator.

In an electric power system, a load with a low power factor draws more current than a load with a high power factor for the same amount of useful power transferred. The higher currents increase the energy lost in the distribution system, and require larger wires and other equipment. Because of the costs of larger equipment and wasted energy, electrical utilities will usually charge a higher cost to industrial or commercial customers where there is a low power factor.

Linear loads with low power factor (such as induction motors) can be corrected with a passive network of capacitors or inductors. Non-linear loads, such as rectifiers, distort the current drawn from the system. In such cases, active or passive power factor correction may be used to counteract the distortion and raise the power factor. The devices for correction of the power factor may be at a central substation, spread out over a distribution system, or built into power-consuming equipment

E5D10 (A)

How can the true power be determined in an AC circuit where the voltage and current are out of phase?

By multiplying the apparent power times the power factor

E5D11 (C)

What is the power factor of an R-L circuit having a 60 degree phase angle between the voltage and the current? **0.5**

Power factor is the cosine of the phase angle. The cosine of 60° is 0.5

E5D12 (B)

How many watts are consumed in a circuit having a power factor of 0.2 if the input is 100-VAC at 4 amperes? **80 watts**

Where the waveforms are purely sinusoidal, the power factor is the cosine of the phase angle (ϕ) between the current and voltage sinusoid waveforms.

Apparent power is 100 volts x 4 amperes or 400 watts. With a power factor of 0.2 there would be an 80 watt loss ($400 \times 0.2 = 80$ watts)

E5D13 (B)

How much power is consumed in a circuit consisting of a 100 ohm resistor in series with a 100 ohm inductive reactance drawing 1 ampere? **100 Watts**

Power = voltage x current or 100 x 1 or 100 watts

E5D14 (A)

What is reactive power? **Wattless, nonproductive power**

In an electric circuit is the rate of flow of energy past a given point of the circuit. In Alternating Current circuits, energy storage elements such as inductors and capacitors may result in periodic reversals of the direction of energy flow. The portion of power that, averaged over a complete cycle of the AC waveform, results in net transfer of energy in one direction is known as active power (sometimes also called real power). The portion of power due to stored energy, which returns to the source in each cycle, is known as reactive power.

E5D15 (D)

What is the power factor of an R-L circuit having a 45 degree phase angle between the voltage and the current? **0.707**

$$\text{Cosine of } 45^\circ = .707$$

E5D16 (C)

What is the power factor of an R-L circuit having a 30 degree phase angle between the voltage and the current? **0.866**

$$\text{Cosine of } 30^\circ = .866$$

E5D17 (D)

How many watts are consumed in a circuit having a power factor of 0.6 if the input is 200VAC at 5 amperes? **600 watts**

*Power consumed = voltage x Current x Power Factor or
200 x 5 x 0.6 or 600 watts*

E5D18 (B)

How many watts are consumed in a circuit having a power factor of 0.71 if the apparent power is 500VA?

355 W

*Power Consumed = Apparent Power x power factor or
500 x .71 or 355 watts*

SUBELEMENT E6

CIRCUIT COMPONENTS

[6 Exam Questions - 6 Groups]

Element 6 Sub-Element A

E6A01 (C)

In what application is gallium arsenide used as a semiconductor material in preference to germanium or silicon? **In microwave circuits**

E6A02 (A)

Which of the following semiconductor materials contains excess free electrons? **N-type**

E6A02 (A)

Which of the following semiconductor materials contains excess free electrons? **N-type**

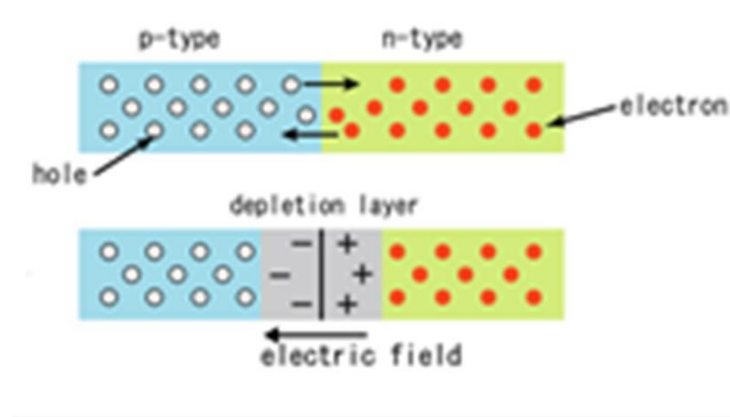

E6A04 (C)

What is the name given to an impurity atom that adds holes to a semiconductor crystal structure? **Acceptor impurity**

E6A05 (C)

What is the alpha of a bipolar junction transistor? **The change of collector current with respect to emitter current**

$$\text{Alpha } (\alpha) = \Delta \text{ collector current} \div \Delta \text{ Emitter Current}$$

E6A06 (B)

What is the beta of a bipolar junction transistor? **The change in collector current with respect to base current**

$$\text{Beta } (\beta) = \Delta \text{ Collector Current} \div \Delta \text{ Base Current}$$

E6A07 (D)

Which of the following indicates that a silicon NPN junction transistor is biased on? **Base-to-emitter voltage of approximately 0.6 to 0.7 volts**

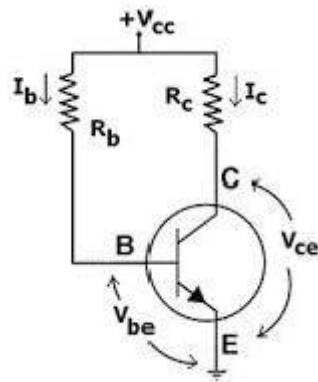

E6A08 (D)

What term indicates the frequency at which the grounded-base current gain of a transistor has decreased to 0.7 of the gain obtainable at 1 kHz?

Alpha cutoff frequency

E6A09 (A)

What is a depletion-mode FET? **An FET that exhibits a current flow between source and drain when no gate voltage is applied**

Figure E6-2

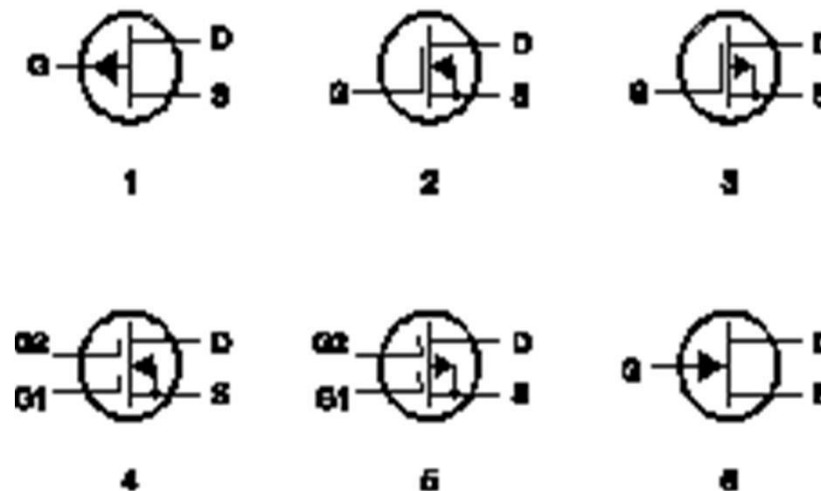

E6A10 (B)

In Figure E6-2, what is the schematic symbol for an N-channel dual-gate MOSFET? **4**

E6A11 (A)

In Figure E6-2, what is the schematic symbol for a P-channel junction FET? **1**

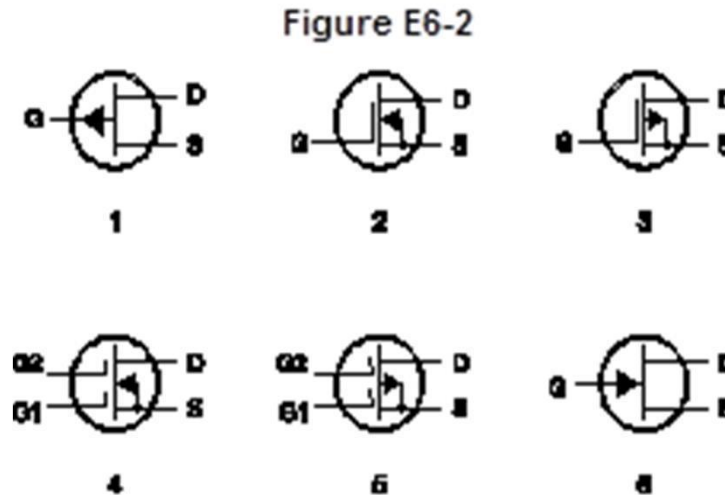

E6A12 (D)

Why do many MOSFET devices have internally connected Zener diodes on the gates? **To reduce the chance of the gate insulation being punctured by static discharges or excessive voltages**

E6A13 (C)

What do the initials CMOS stand for? **Complementary Metal-Oxide Semiconductor**

E6A14 (C)

How does DC input impedance at the gate of a field-effect transistor compare with the DC input impedance of a bipolar transistor? **An FET has high input impedance; a bipolar transistor has low input impedance**

E6A15 (B)

Which semiconductor material contains excess holes in the outer shell of electrons? **P-type**

E6A16 (B)

What are the majority charge carriers in N-type semiconductor material? **Free electrons**

E6A17 (D)

What are the names of the three terminals of a field-effect transistor? **Gate, drain, source**

Element 6 Sub-Element B

E6B01 (B)

What is the most useful characteristic of a Zener diode?
A constant voltage drop under conditions of varying current

E6B02 (D)

What is an important characteristic of a Schottky diode as compared to an ordinary silicon diode when used as a power supply rectifier? **Less forward voltage drop**

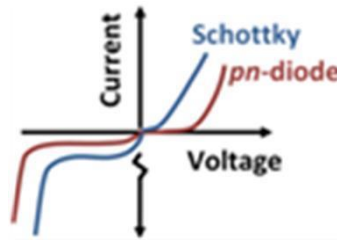

E6B03 (C)

What special type of diode is capable of both amplification and oscillation? **Tunnel**

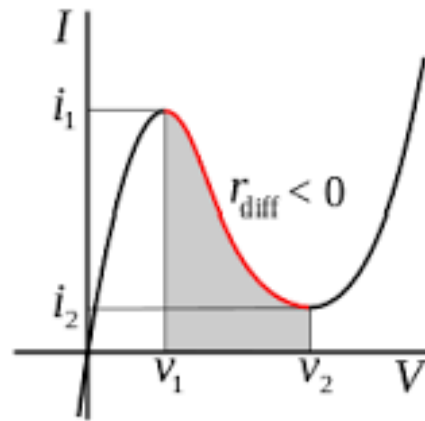

E6B04 (A)

What type of semiconductor device is designed for use as a voltage-controlled capacitor? **Varactor diode**

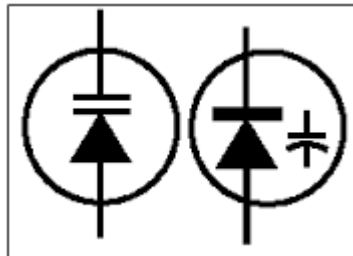

E6B05 (D)

What characteristic of a PIN diode makes it useful as an RF switch or attenuator? **A large region of intrinsic material**

A PIN diode is a diode with a wide, undoped intrinsic semiconductor region between a p-type semiconductor and an n-type semiconductor region. Pin diodes are used as switches and as voltage controlled attenuators in microwave circuits.

E6B06 (D)

Which of the following is a common use of a hot-carrier diode? **As a VHF/UHF mixer or detector**

A hot carrier diode, is a semiconductor diode with a low forward voltage drop and a very fast switching action. When forward current flows through a solid-state diode, there is a small voltage drop across its terminals.

E6B07 (B)

What is the failure mechanism when a junction diode fails due to excessive current? **Excessive junction temperature**

E6B08 (A)

Which of the following describes a type of semiconductor diode? **Metal-semiconductor junction**

E6B09 (C)

What is a common use for point contact diodes? **As an RF detector**

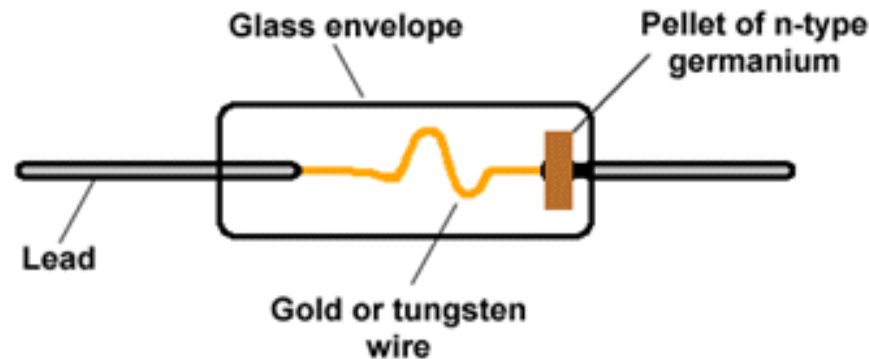

E6B10 (B)

In Figure E6-3, what is the schematic symbol for a light-emitting diode? **5**

Figure E6-3

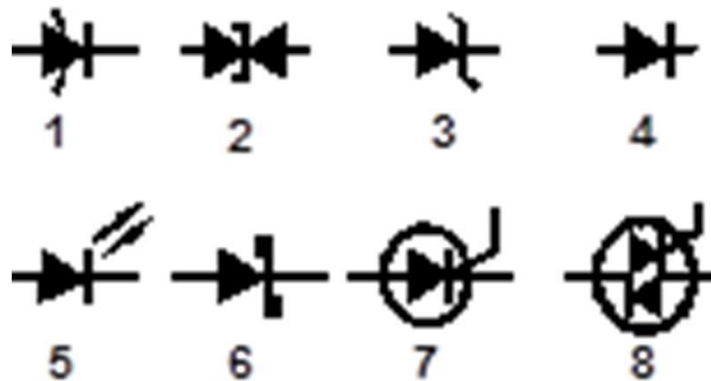

E6B12 (C)

What is one common use for PIN diodes?
switch

As an RF

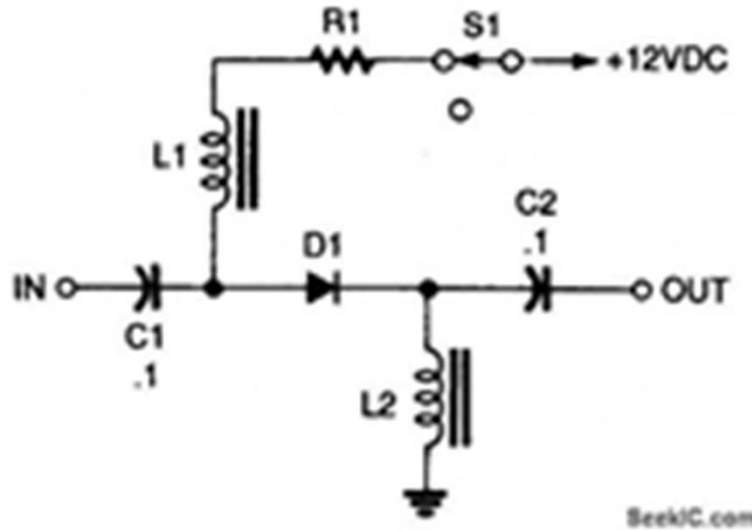

E6B13 (B)

What type of bias is required for an LED to emit light?
Forward bias

Element 6 Sub-Element C

E6C01 (A)

What is the function of hysteresis in a comparator? **To prevent input noise from causing unstable output signals**

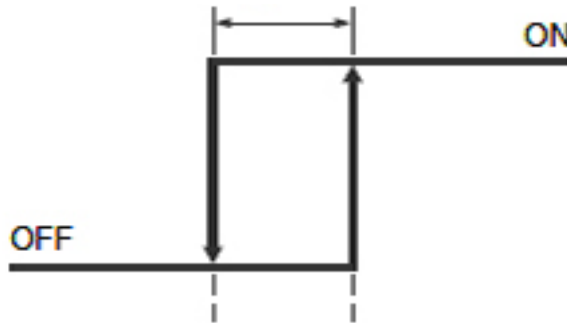

E6C02 (B)

What happens when the level of a comparator's input signal crosses the threshold? **The comparator changes its output state**

E6C03 (A)

What is tri-state logic? **Logic devices with 0, 1, and high impedance output states**

E6C04 (B)

What is the primary advantage of tri-state logic? **Ability to connect many device outputs to a common bus**

E6C05 (D)

What is an advantage of CMOS logic devices over TTL devices? **Lower power consumption**

CMOS stands for Complementary Metal Oxide Semiconductor

E6C06 (C)

Why do CMOS digital integrated circuits have high immunity to noise on the input signal or power supply?

The input switching threshold is about one-half the power supply voltage

This means higher immunity false triggers from noise.

E6C07 (B)

What best describes a pull-up or pull-down resistor? **A resistor connected to the positive or negative supply line used to establish a voltage when an input or output is an open circuit**

Figure E6-5

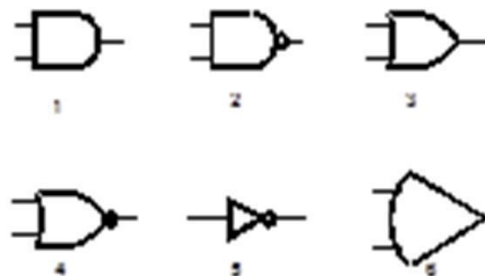

E6C08 (B)

In Figure E6-5, what is the schematic symbol for a NAND gate? **2**

E6C09 (B)

What is a Programmable Logic Device (PLD)? **A programmable collection of logic gates and circuits in a single integrated circuit**

Figure E6-5

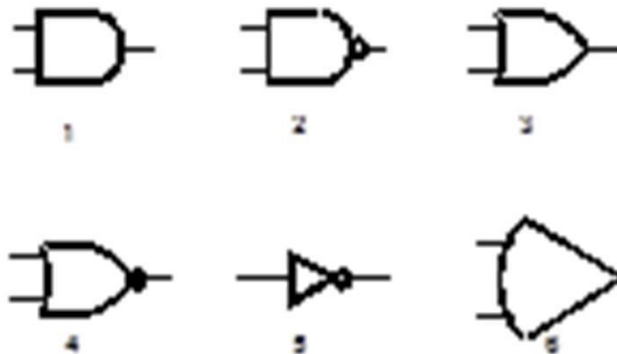

E6C10 (D)

In Figure E6-5, what is the schematic symbol for a NOR gate? **4**

E6C11 (C)

In Figure E6-5, what is the schematic symbol for the NOT operation (inverter)?

5

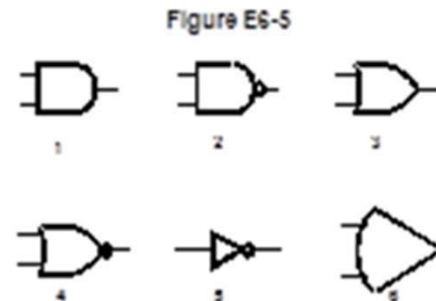

E6C12 (D)

What is BiCMOS logic? **An integrated circuit logic family using both bipolar and CMOS transistors**

BiCMOS combines the strengths of two different process technologies into a single chip: Bipolar transistors offer high speed and gain, which are critical for high-frequency analog sections, whereas CMOS technology excels for constructing simple, low-power logic gates.

E6C13 (C)

Which of the following is an advantage of BiCMOS logic? **It has the high input impedance of CMOS and the low output impedance of bipolar transistors**

E6C14 (B)

What is the primary advantage of using a Programmable Gate Array (PGA) in a logic circuit?

Complex logic functions can be created in a single integrated circuit

Element 6 Sub-Element D

E6D01 (A)

How many turns will be required to produce a 5-microhenry inductor using a powdered-iron toroidal core that has an inductance index (A L) value of 40 micro-henrys /100 turns? **35 turns**

$$N(\text{turns}) = \text{turns} \sqrt{(\text{desired } L \div L \text{ for turns})} \text{ or}$$
$$100\sqrt{(5 \div 40)} \text{ or } 100 \times .353 \text{ or } 35$$

E6D02 (A)

What is the equivalent circuit of a quartz crystal?

Motional capacitance, motional inductance, and loss resistance in series, all in parallel with a shunt capacitor representing electrode and stray capacitance

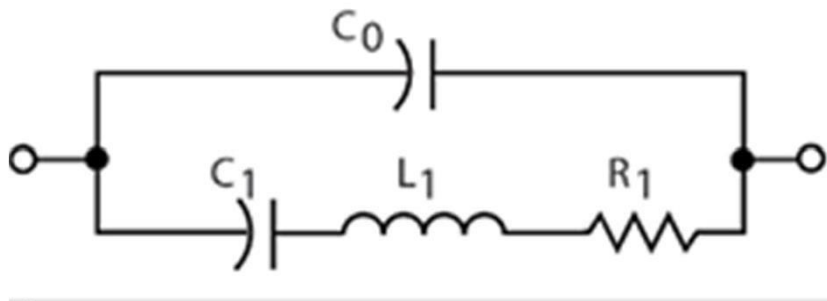

E6D03 (A)

Which of the following is an aspect of the piezoelectric effect?

Mechanical deformation of material by the application of a voltage

E6D04 (B)

Which materials are commonly used as a slug core in a variable inductor? **Ferrite and brass**

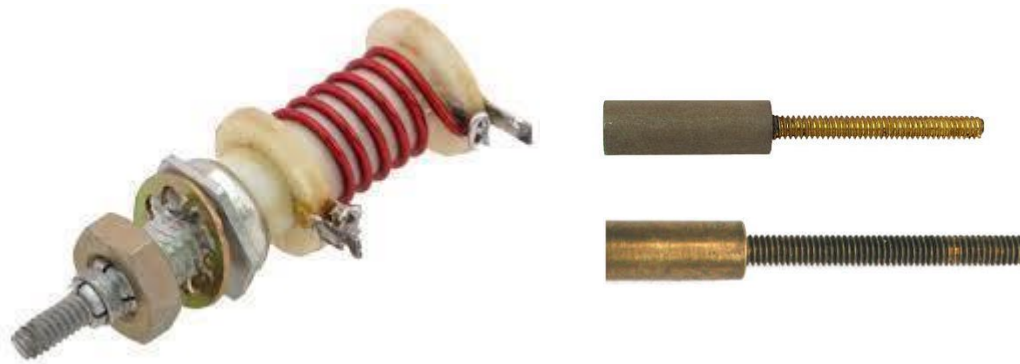

E6D05 (C)

What is one reason for using ferrite cores rather than powdered-iron in an inductor? **Ferrite toroids generally require fewer turns to produce a given inductance value**

E6D06 (D)

What core material property determines the inductance of a toroidal inductor? **Permeability**

permeability is the measure of the ability of a material to support the formation of a magnetic field within itself.



E6D07 (B)

What is the usable frequency range of inductors that use toroidal cores, assuming a correct selection of core material for the frequency being used? **From less than 20 Hz to approximately 300 MHz**

E6D08 (B)

What is one reason for using powdered-iron cores rather than ferrite cores in an inductor?

Powdered-iron cores generally maintain their characteristics at higher currents

E6D09 (C)

What devices are commonly used as VHF and UHF parasitic suppressors at the input and output terminals of a transistor HF amplifier? **Ferrite beads**



E6D10 (A)

What is a primary advantage of using a toroidal core instead of a solenoidal core in an inductor?

Toroidal cores confine most of the magnetic field within the core material

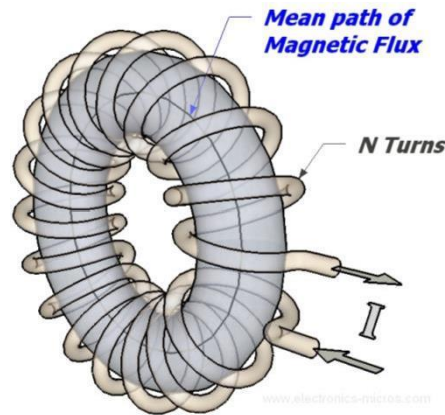

E6D11 (C)

How many turns will be required to produce a 1-mH inductor using a core that has an inductance index (A L) value of 523 millihenrys/1000 turns? **43 turns**

$$\# \text{ turns} = \sqrt{((\text{desired } L(\mu\text{H})) \div (\mu\text{H} / \text{turns}))}$$

$$\text{or } \# \text{ turns} = \sqrt{(1000 \div (523 \div 1000))} \text{ or } 43.7$$

E6D12 (C)

What is the definition of saturation in a ferrite core inductor? **The ability of the inductor's core to store magnetic energy has been exceeded**

E6D13 (A)

What is the primary cause of inductor self-resonance? **Inter-turn capacitance**

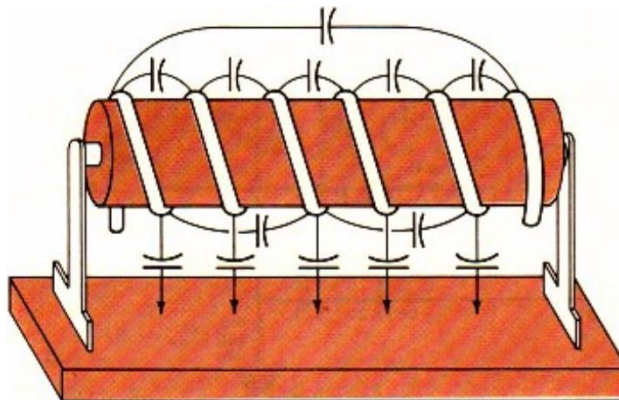

E6D14 (B)

Which type of slug material decreases inductance when inserted into a coil? **Brass**

E6D15 (A)

What is current in the primary winding of a transformer called if no load is attached to the secondary?

Magnetizing current

E6D16 (D)

What is the common name for a capacitor connected across a transformer secondary that is used to absorb transient voltage spikes? **Snubber capacitor**

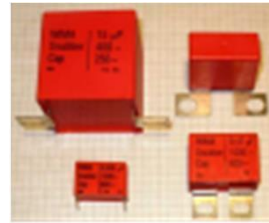
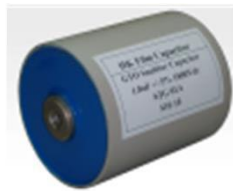

E6D17 (A)

Why should core saturation of a conventional impedance matching transformer be avoided?

Harmonics and distortion could result

Element 6 Sub-Element E

E6E01 (C)

Which of the following is true of a charge-coupled device (CCD)? **It samples an analog signal and passes it in stages from the input to the output**

E6E02 (A)

Which of the following device packages is a through-hole type? **DIP**



E6E03 (D)

Which of the following materials is likely to provide the highest frequency of operation when used in MMICs?

Gallium nitride

E6E04 (A)

Which is the most common input and output impedance of circuits that use MMICs? **50 ohms**

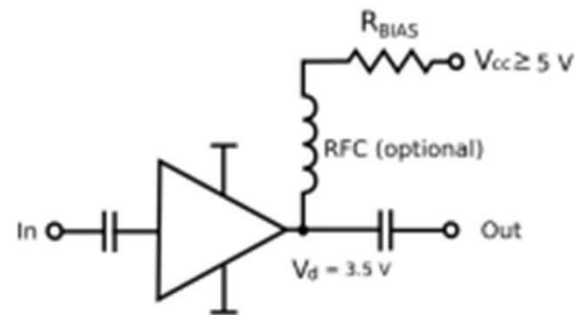
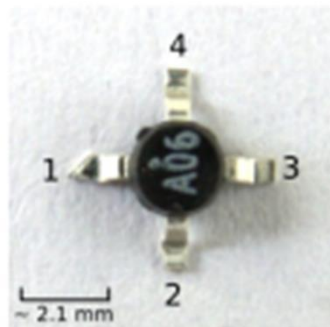

E6E05 (A)

Which of the following noise figure values is typical of a low-noise UHF preamplifier? 2 dB

The noise figure of amplifiers is always positive (they do add some noise) and have a small dB value

E6E06 (D)

What characteristics of the MMIC make it a popular choice for VHF through microwave circuits?

Controlled gain, low noise figure, and constant input and output impedance over the specified frequency range

E6E07 (B)

Which of the following is typically used to construct a MMIC-based microwave amplifier?

Microstrip construction

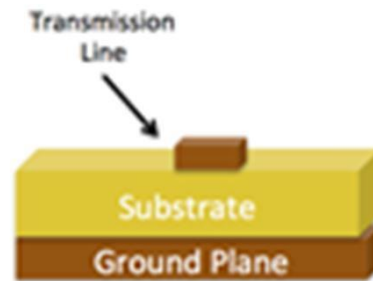

E6E08 (A)

How is voltage from a power supply normally furnished to the most common type of monolithic microwave integrated circuit (MMIC)? **Through a resistor and/or RF choke connected to the amplifier output lead**

E6E09 (D)

Which of the following component package types would be most suitable for use at frequencies above the HF range? **Surface mount**

E6E10 (D)

What is the packaging technique in which leadless components are soldered directly to circuit boards?

Surface mount

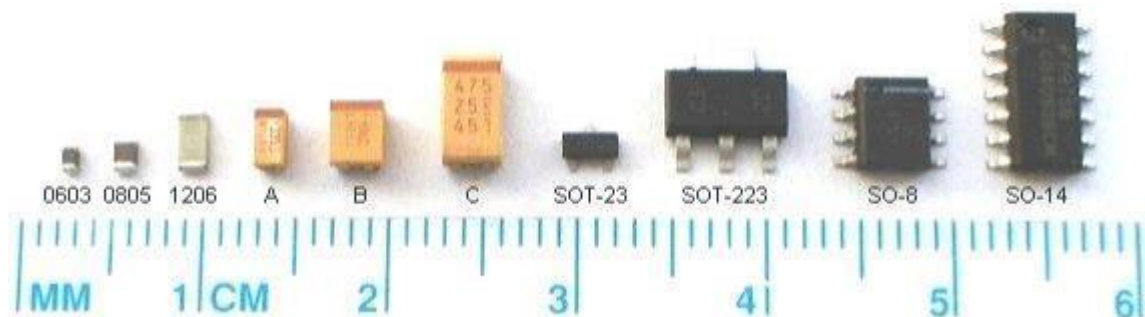

E6E11 (D)

What is a characteristic of DIP packaging used for integrated circuits? **A total of two rows of connecting pins placed on opposite sides of the package (Dual In-line Package)**



E6E12 (B)

Why are high-power RF amplifier ICs and transistors sometimes mounted in ceramic packages? **Better dissipation of heat**

Element 6 Sub-Element F

E6F01 (B)

What is photoconductivity? **The increased conductivity of an illuminated semiconductor**

Increased conductivity means a lower resistance.

E6F02 (A)

What happens to the conductivity of a photoconductive material when light shines on it? **It increases**

The resistance decreases with light shining on the device.

E6F03 (D)

What is the most common configuration of an optoisolator or optocoupler? **An LED and a phototransistor**

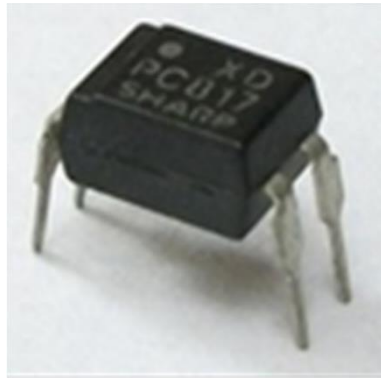
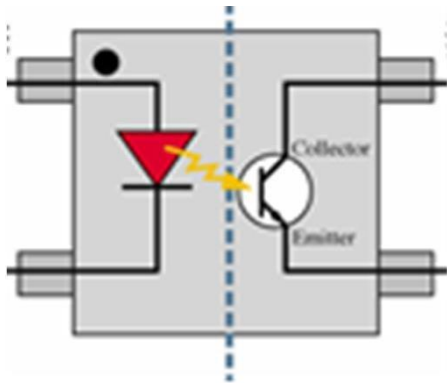

E6F04 (B)

What is the photovoltaic effect? **The conversion of light to electrical energy**

E6F05 (A)

Which describes an optical shaft encoder? **A device which detects rotation of a control by interrupting a light source with a patterned wheel**

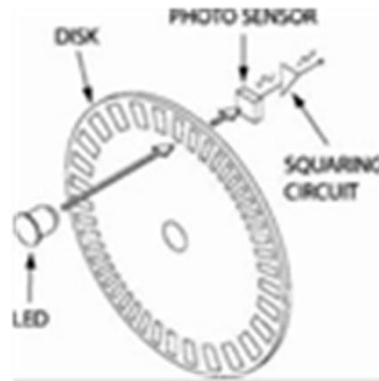

E6F06 (A)

Which of these materials is affected the most by photoconductivity? **A crystalline semiconductor**

E6F07 (B)

What is a solid state relay? **A device that uses semiconductors to implement the functions of an electromechanical relay**

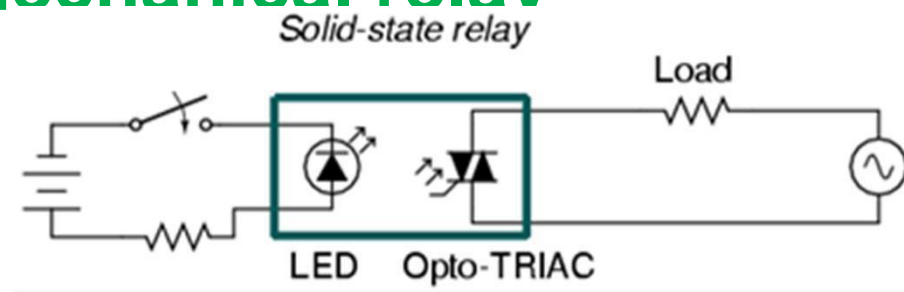

E6F08 (C)

Why are optoisolators often used in conjunction with solid state circuits when switching 120VAC?

Optoisolators provide a very high degree of electrical isolation between a control circuit and the circuit being switched

E6F08 (C)

Why are optoisolators often used in conjunction with solid state circuits when switching 120VAC?

Optoisolators provide a very high degree of electrical isolation between a control circuit and the circuit being switched

E6F09 (D)

What is the efficiency of a photovoltaic cell? **The relative fraction of light that is converted to current**

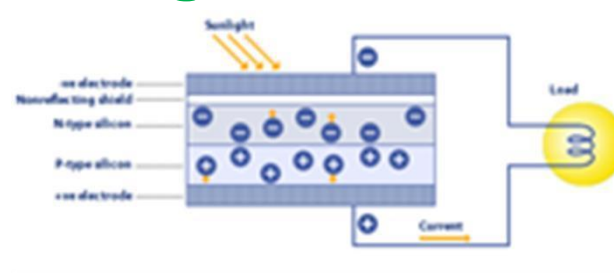

E6F10 (B)

What is the most common type of photovoltaic cell used for electrical power generation? **Silicon**

E6F11 (B)

What is the approximate open-circuit voltage produced by a fully-illuminated silicon photovoltaic cell? **0.5 V**

E6F12 (C)

What absorbs the energy from light falling on a photovoltaic cell? **Electrons**

E6F13 (B)

What is a liquid crystal display (LCD)? **A display utilizing a crystalline liquid and polarizing filters which becomes opaque when voltage is applied**



E6F14 (B)

Which of the following is true of LCD displays? **They may be hard view through polarized lenses**

ELEMENT E7
PRACTICAL CIRCUITS
[8 Exam Questions - 8 Groups]

Element 7 Sub-Element A

E7A01 (C)

Which is a bi-stable circuit? **A flip-flop**

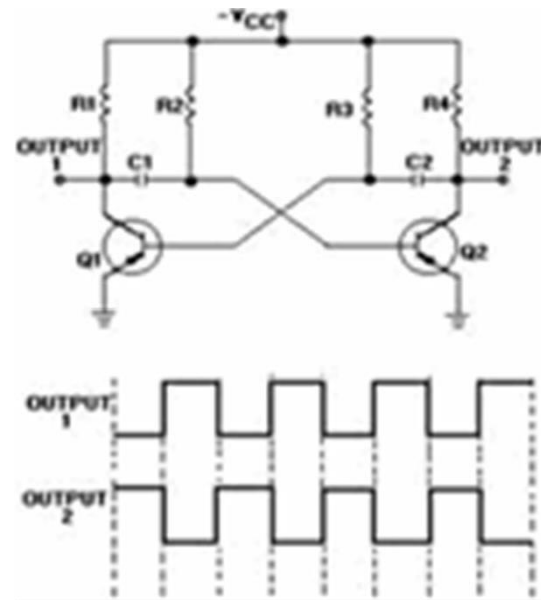
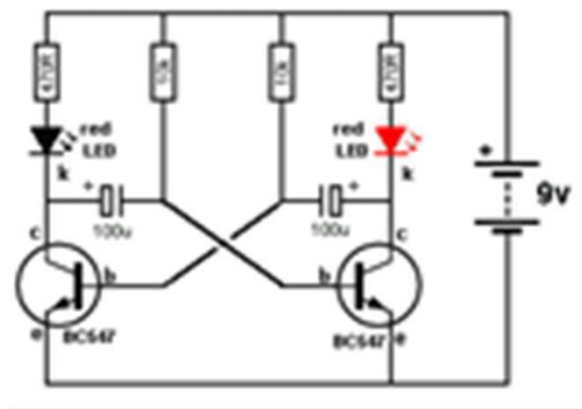

E7A02 (A)

What is the function of a decade counter digital IC? **It produces one output pulse for every ten input pulses**

$$\text{output} = \text{input} \div 10$$

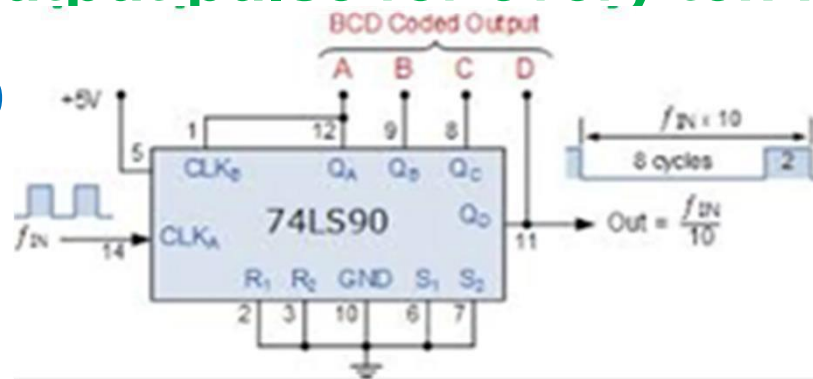

E7A03 (B)

Which of the following can divide the frequency of a pulse train by 2? **A flip-flop**

$$\text{output} = \text{input} \div 2$$

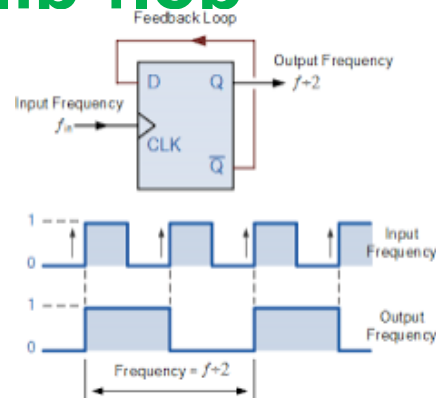

E7A05 (D)

Which of the following is a circuit that continuously alternates between two states without an external clock? **Astable multivibrator**

The Astable Multivibrator is another type of cross-coupled transistor switching circuit that has NO stable output states as it changes from one state to the other all the time. The astable circuit consists of two switching transistors, a cross-coupled feedback network, and two time delay capacitors which allows oscillation between the two states with no external triggering to produce the change in state.

E7A06 (A)

What is a characteristic of a monostable multivibrator?
It switches momentarily to the opposite binary state and then returns to its original state after a set time

A monostable Multivibrator has only ONE stable state (hence their name: “Mono”), and produce a single output pulse when it is triggered externally. Monostable Multivibrators only return back to their first original and stable state after a period of time determined by the time constant of the RC coupled circuit.

E7A07 (D)

What logical operation does a NAND gate perform? **It produces logic "0" at its output only when all inputs are logic "1"**

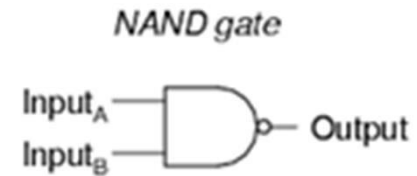

A	B	Output
0	0	1
0	1	1
1	0	1
1	1	0

E7A08 (A)

What logical operation does an OR gate perform? **It produces logic "1" at its output if any or all inputs are logic "1"**

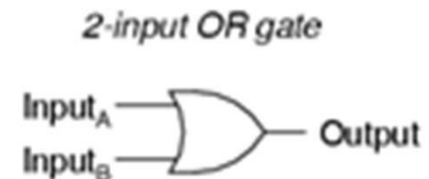

A	B	Output
0	0	0
0	1	1
1	0	1
1	1	1

E7A09 (C)

What logical operation is performed by an exclusive NOR gate? **It produces logic "0" at its output if any single input is logic "1"**

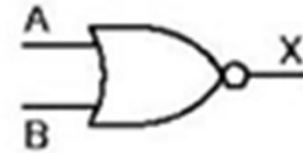

A	B	X
0	0	1
0	1	0
1	0	0
1	1	0

E7A10 (C)

What is a truth table? **A list of inputs and corresponding outputs for a digital device**

INPUTS		OUTPUTS					
A	B	AND	NAND	OR	NOR	EXOR	EXNOR
0	0	0	1	0	1	0	1
0	1	0	1	1	0	1	0
1	0	0	1	1	0	1	0
1	1	1	0	1	0	0	1

E7A11 (D)

What type of logic defines "1" as a high voltage?

Positive Logic

E7A12 (C)

What type of logic defines "0" as a high voltage?

Negative logic

Element 7 Sub-Element B

Amplifier Type/Class Tutorial

Power amplifiers are classified primarily by the design of the output stage. Classification is based on the amount of time the output device(s) operate during each cycle of the input signal.

Class A operation is where the tube or semiconductor device conducts continuously for the entire cycle of the input signal, or a bias current flows in the output devices at all times. The key ingredient of class A operation is that the output is always on. Conversely the output device is never turned off. Because of this, class A amplifiers are single-ended designs. Class A is the most inefficient of all power amplifier designs, averaging only around 20%. Because of this, class A amplifiers are large, heavy and run very hot. On the positive side, class A designs are inherently the most linear, and have the least amount of distortion.

When driving an A class amplifier care should be taken to insure the peak to peak input voltage stays within the linear range of the amplifier.

Class B operation has conduction occurring for only for $\frac{1}{2}$ of the input cycle. Class B amplifiers typically have dual output devices operating 180° out of phase with each other in a push / pull configuration to allow the full cycle of the input to be amplified. Both output devices are never allowed to be on at the same time, bias is set so that current flow in a specific output device is zero without an input signal. Current only flows in each of the push / pull amplifier output amplifiers for one half cycle. Thus each output amplifier is only on for $\frac{1}{2}$ of a complete sinusoidal signal cycle. Class B push pull designs show high efficiency but poor linearity around the 0 voltage crossover region. This is due to the time it takes to turn one device off and the other device on, which translates into extreme crossover distortion. Thus restricting class B designs to power consumption critical applications, e.g., battery operated equipment.

Class B push / pull transmitter power amplifiers reduce or prevent even order harmonics in the output signal.

Class AB operation allows both devices to be on at the same time (like in class A), but just barely. The output bias is set so that current flows in a specific output device appreciably more than a half cycle but less than the entire cycle. That is, only a small amount of current is allowed to flow through both devices, unlike the complete load current of class A designs, but enough to keep each device operating so they respond instantly to input voltage demands. Thus the inherent non-linearity of class B designs is eliminated, without the gross inefficiencies of the class A design. It is this combination of good efficiency (around 50%) with excellent linearity that makes class AB the most popular audio amplifier design.

Class C operation allows current flows for less than one half cycle of the input signal. The class C operation is achieved by reverse biasing the amplifier to point below cutoff and allows only the portion of the input signal that overcomes the reverse bias to cause current flow. The class C operated amplifier is used as a radio-frequency amplifier in frequency modulated or CW transmitters.

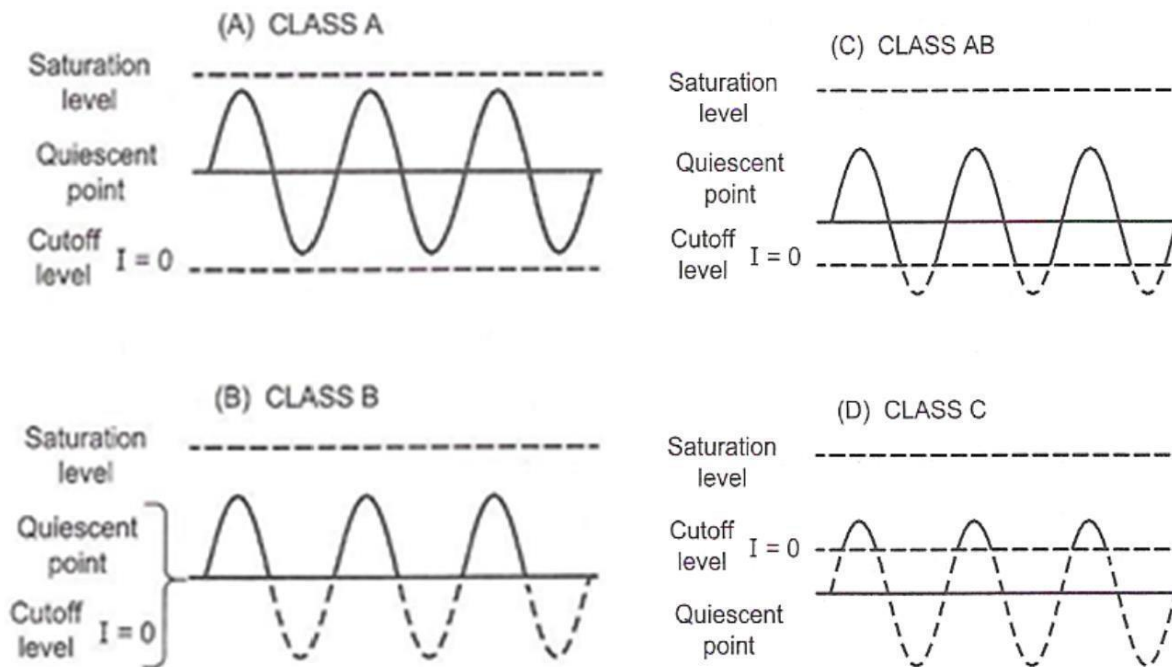

E7B01 (A)

For what portion of a signal cycle does a Class AB amplifier operate? **More than 180 degrees but less than 360 degrees**

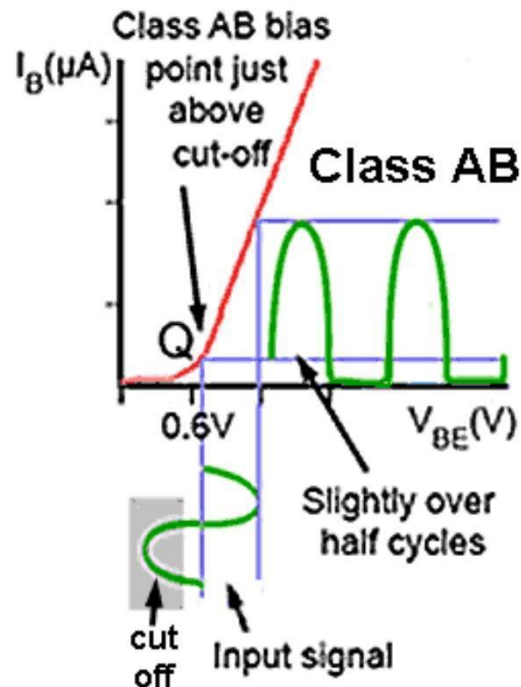

E7B02 (A)

What is a Class D amplifier? **A type of amplifier that**

uses switching technology to achieve high efficiency

Class-D amplifier or switching amplifier is an electronic amplifier in which the amplifying devices operate as electronic switches, and not as linear gain devices as in other amplifiers. The signal to be amplified is a train of constant amplitude pulses, so the active devices switch rapidly back and forth between a fully conductive and nonconductive state. The analog signal to be amplified is converted to a series of pulses by pulse width modulation before being applied to the amplifier. After amplification, the output pulse train can be converted back to an analog signal by passing through a passive low pass filter consisting of inductors and capacitors. The major advantage of a class-D amplifier is that it can be more efficient than analog amplifiers, with less power dissipated as heat in the active devices.

E7B03 (A)

Which of the following components form the output of a class D amplifier circuit? **A low-pass filter to remove switching signal components**

E7B04 (A)

Where on the load line of a Class A common emitter amplifier would bias normally be set? **Approximately half-way between saturation and cutoff**

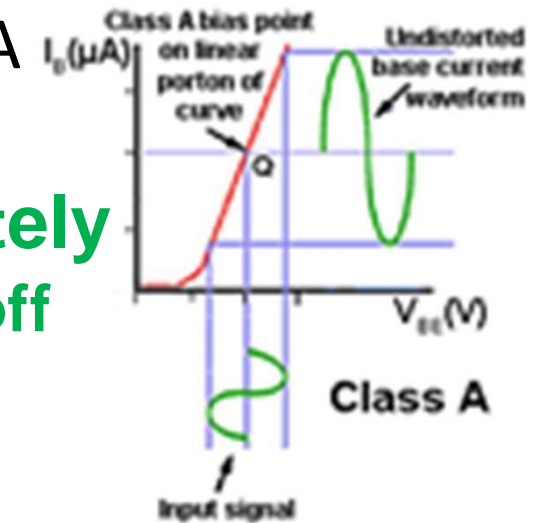

E7B05 (C)

What can be done to prevent unwanted oscillations in an RF power amplifier? **Install parasitic suppressors and/or neutralize the stage**

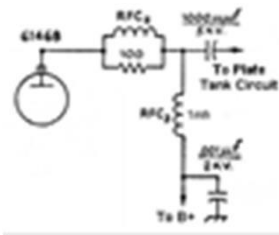

E7B06 (B)

Which of the following amplifier types reduces or eliminates even order harmonics? **Push-pull**

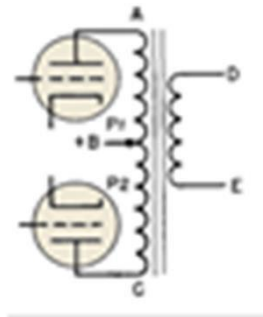
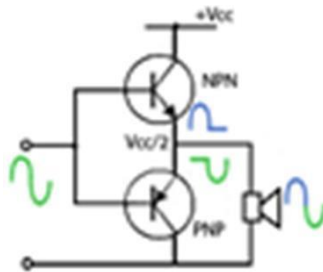

E7B07 (D)

Which of the following is a likely result when a Class C amplifier is used to amplify a single-sideband phone signal? **Signal distortion and excessive bandwidth**

E7B08 (C)

How can an RF power amplifier be neutralized? **By feeding a 180-degree out-of-phase portion of the output back to the input**

E7B09 (D)

Which of the following describes how the loading and tuning capacitors are to be adjusted when tuning a vacuum tube RF power amplifier that employs a Pi-network output circuit? **The tuning capacitor is adjusted for minimum plate current, and the loading capacitor is adjusted for maximum permissible plate current**

E7B10 (B)

In Figure E7-1, what is the purpose of R1 and R2? **Fixed bias**

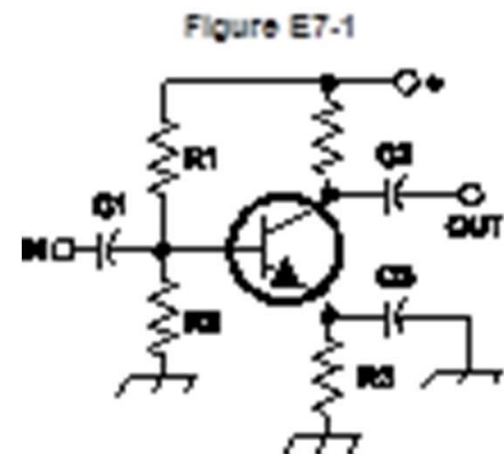

E7B11 (D)

In Figure E7-1, what is the purpose of R3? **Self-bias**

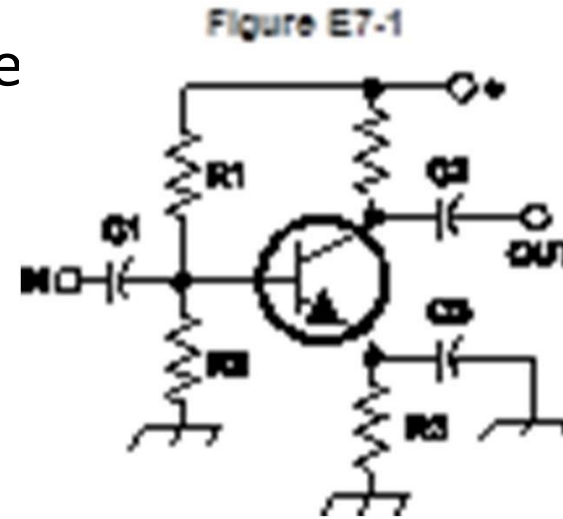

E7B12 (C)

What type of amplifier circuit is shown in Figure E7-1? **Common emitter**

E7B13 (A)

In Figure E7-2, what is the purpose of R? **Emitter load**

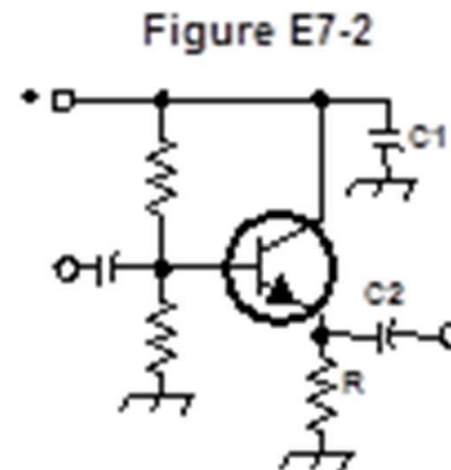

E7B14 (B)

Why are switching amplifiers more efficient than linear amplifiers? **The power transistor is at saturation or cut off most of the time, resulting in low power dissipation**

E7B15 (C)

What is one way to prevent thermal runaway in a bipolar transistor amplifier? **Use a resistor in series with the emitter**

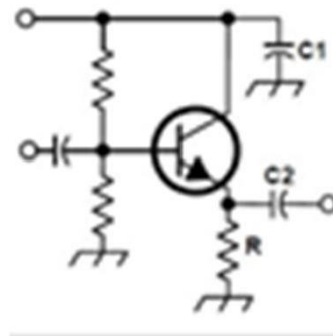

E7B16 (A)

What is the effect of intermodulation products in a linear power amplifier? **Transmission of spurious signals**

E7B17 (A)

Why are odd-order rather than even-order intermodulation distortion products of concern in linear power amplifiers? **Because they are relatively close in frequency to the desired signal**

E7B18 (C)

What is a characteristic of a grounded-grid amplifier? **Low input impedance**

Element 7 Sub-Element C

E7C01 (D)

How are the capacitors and inductors of a low-pass filter Pi-network arranged between the network's input and output? **A capacitor is connected between the input and ground, another capacitor is connected between the output and ground, and an inductor is connected between input and output**

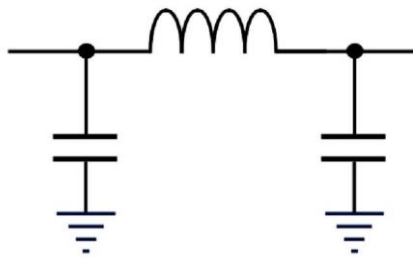

E7C02 (C)

Which of the following is a property of a T-network with series capacitors and a parallel shunt inductor?

It is a high-pass filter

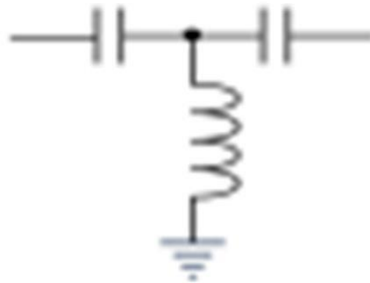

E7C03 (A)

What advantage does a Pi-L-network have over a regular Pi-network for impedance matching between the final amplifier of a vacuum-tube transmitter and an antenna?

Greater harmonic suppression

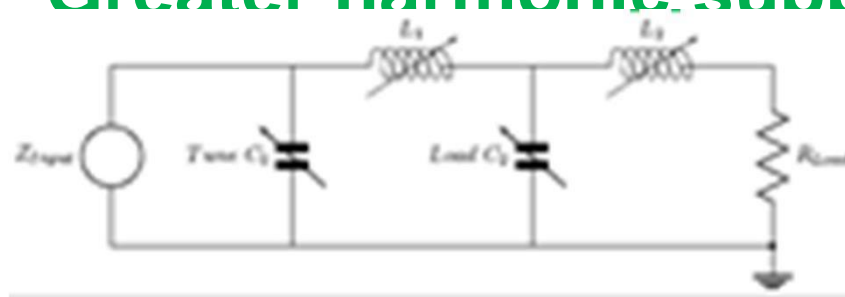

E7C04 (C)

How does an impedance-matching circuit transform a complex impedance to a resistive impedance?

It cancels the reactive part of the impedance and changes the resistive part to a desired value

E7C05 (D)

Which filter type is described as having ripple in the passband and a sharp cutoff?

Chebyshev filter

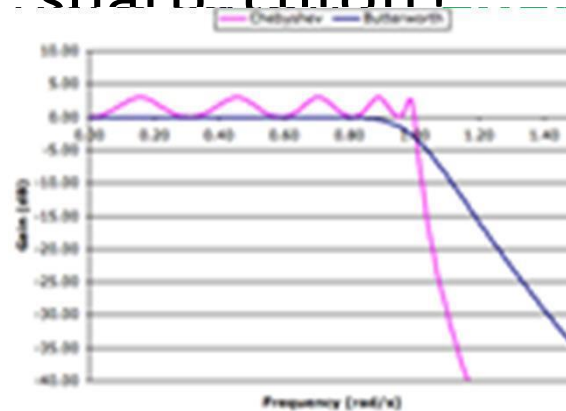

E7C06 (C)

What are the distinguishing features of an elliptical filter? **Extremely sharp cutoff with one or more notches in the stop band**

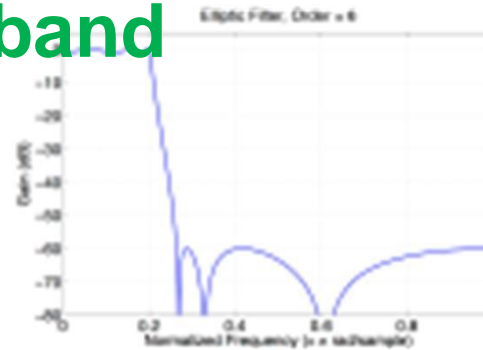

E7C07 (B)

What kind of filter would you use to attenuate an interfering carrier signal while receiving an SSB transmission? **A notch filter**

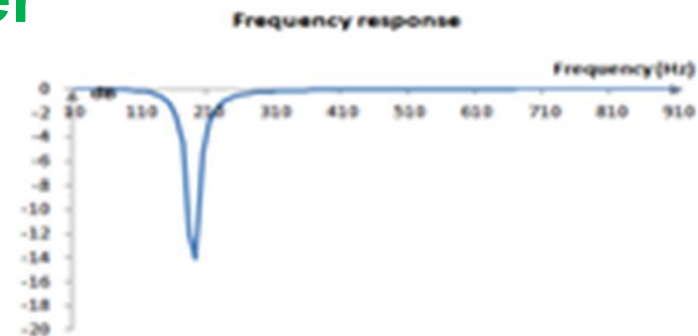

E7C08 (A)

Which of the following factors has the greatest effect in helping determine the bandwidth and response shape of a crystal ladder filter? **The relative frequencies of the individual crystals**

Crystal filter with four crystals (known as a Crystal Ladder filter). All crystals are matched:

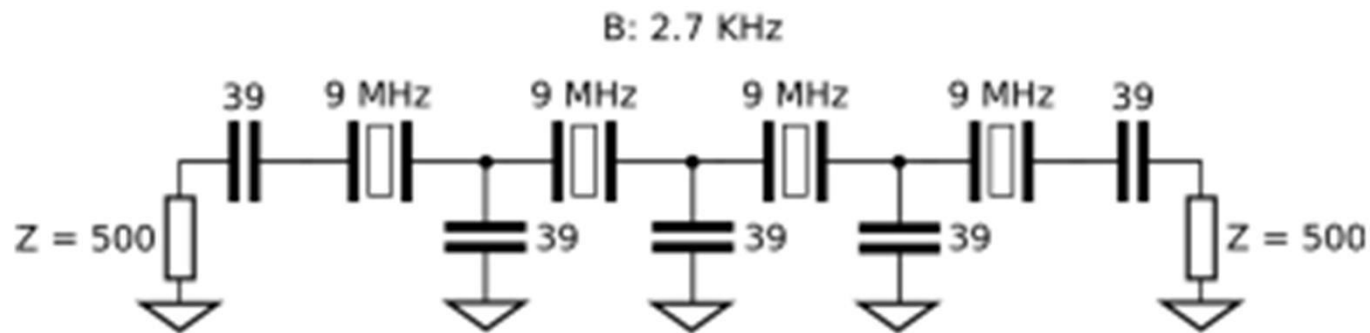

E7C09 (B)

What is a Jones filter as used as part of an HF receiver IF stage? **A variable bandwidth crystal lattice filter**

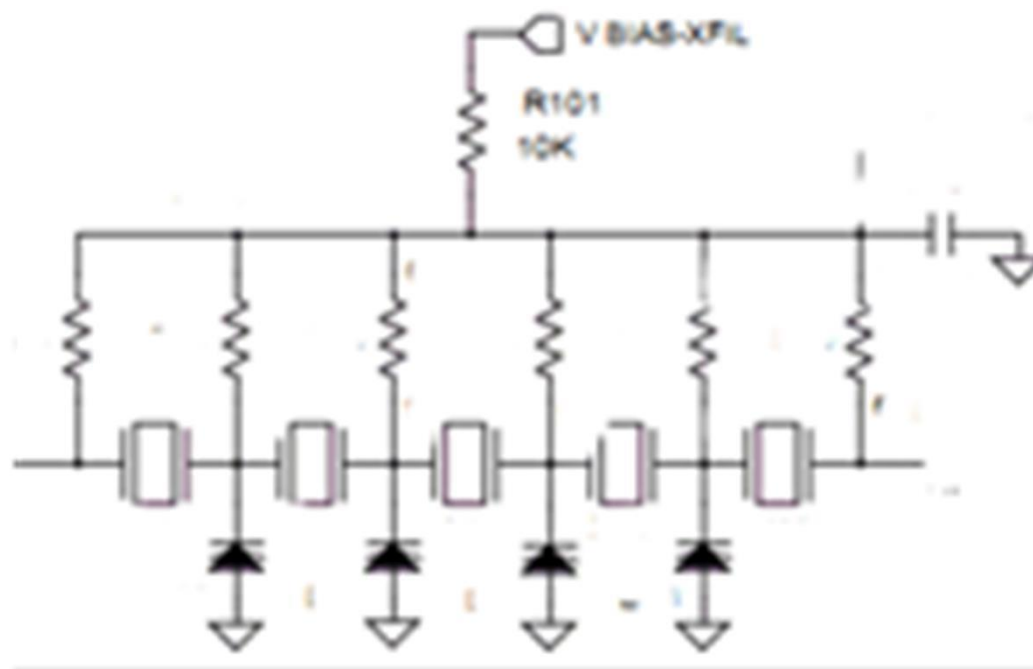

E7C10 (B)

Which of the following filters would be the best choice for use in a 2 meter repeater duplexer? **A cavity filter**

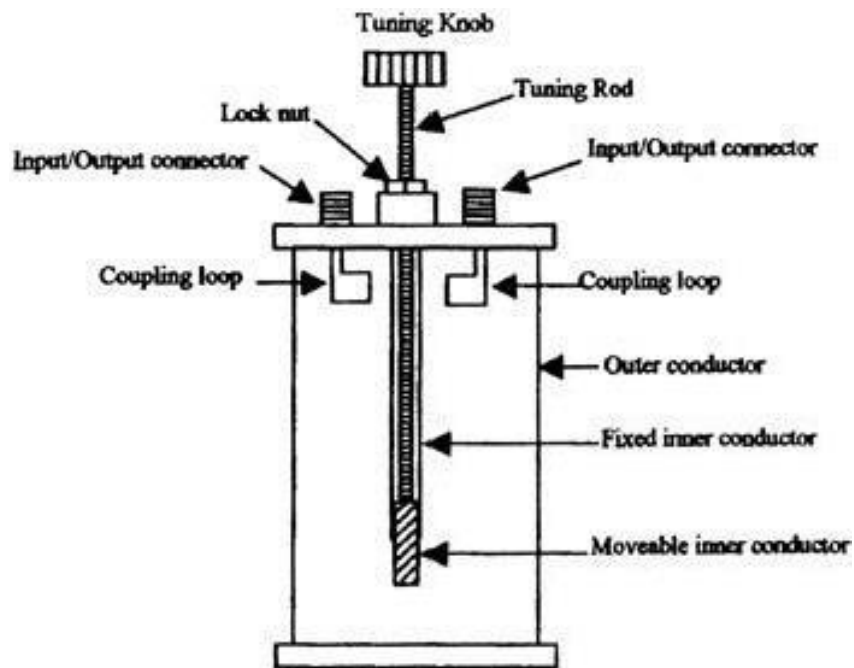

E7C11 (D)

Which of the following is the common name for a filter network which is equivalent to two L-networks connected back-to-back with the two inductors in series and the capacitors in shunt at the input and output? **Pi**

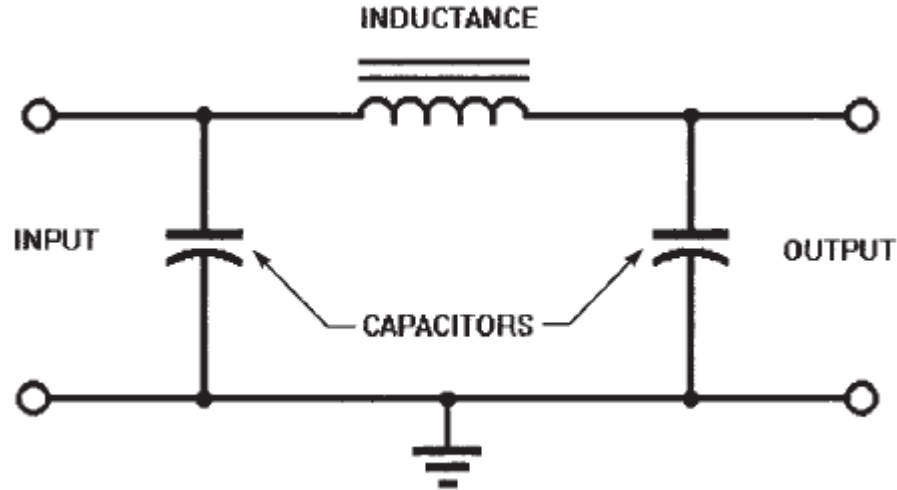

E7C12 (B)

Which describes a Pi-L-network used for matching a vacuum tube final amplifier to a 50 ohm unbalanced output? **A Pi-network with an additional series inductor on the output**

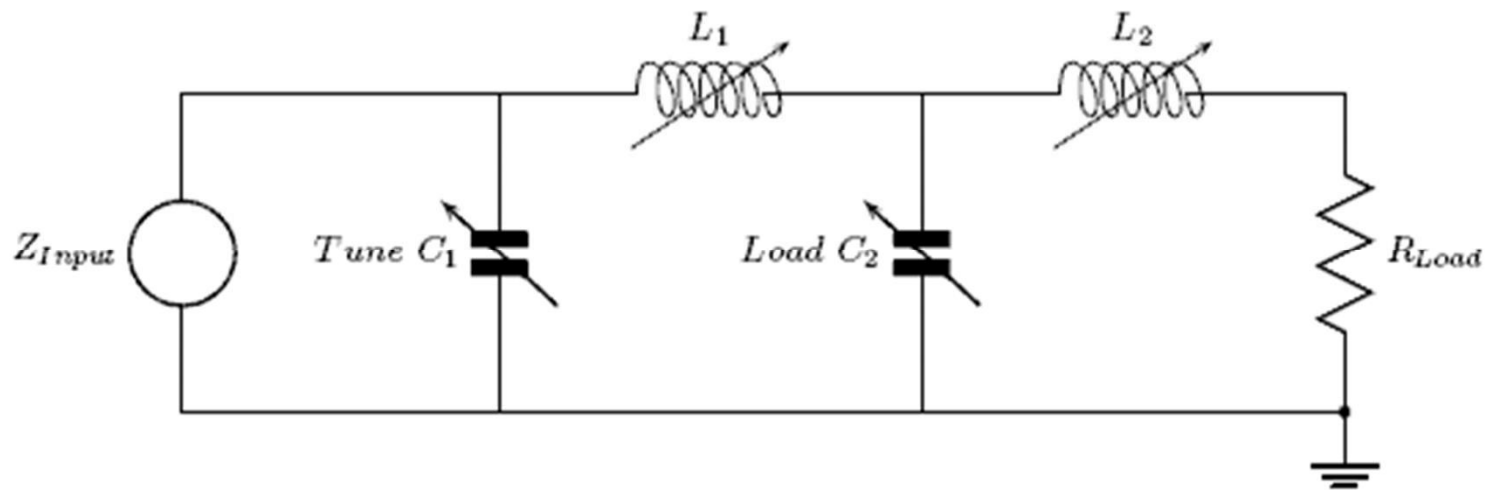

E7C13 (A)

What is one advantage of a Pi-matching network over an L-matching network consisting of a single inductor and a single capacitor? **The Q of Pi-networks can be varied depending on the component values chosen**

E7C14 (C)

Which mode is most affected by non-linear phase response in a receiver IF filter? **Digital**

E7C15 (D)

What is a crystal lattice filter? **A filter with narrow bandwidth and steep skirts made using quartz**

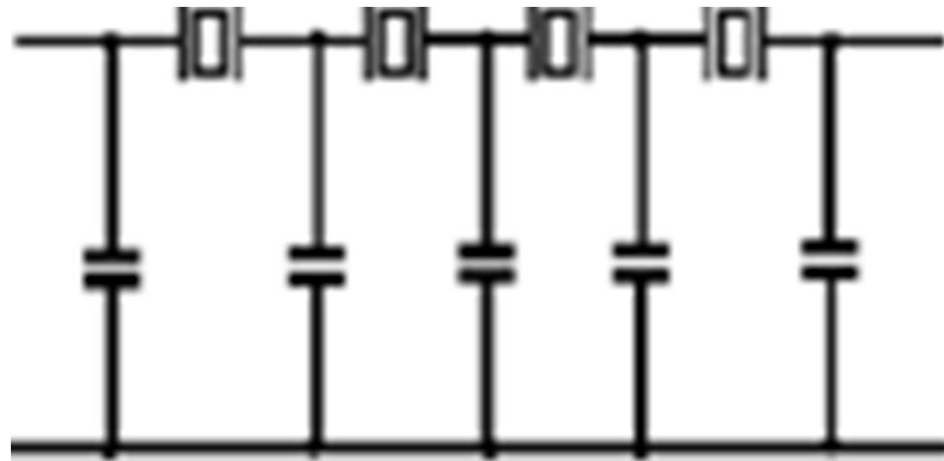

Element 7 Sub-Element D

E7D01 (D)

What is one characteristic of a linear electronic voltage regulator? **The conduction of a control element is varied to maintain a constant output voltage**

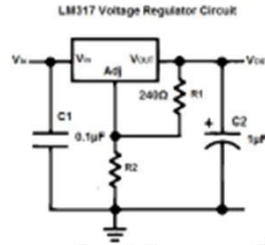

E7D02 (C)

What is one characteristic of a switching electronic voltage regulator? **The controlled device's duty cycle is changed to produce a constant average output voltage**

E7D02 (C)

What is one characteristic of a switching electronic voltage regulator? **The controlled device's duty cycle is changed to produce a constant average output voltage**

E7D03 (A)

What device is typically used as a stable reference voltage in a linear voltage regulator?

A Zener diode

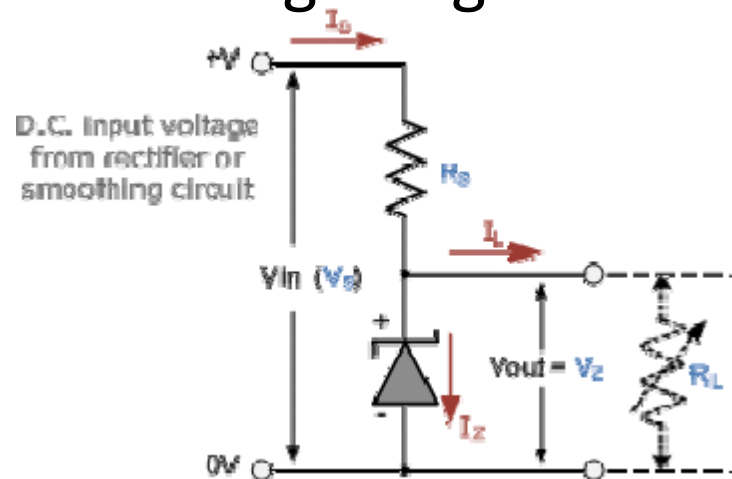

E7D05 (D)

Which of the following types of linear voltage regulator places a constant load on the unregulated voltage source? **A shunt regulator**

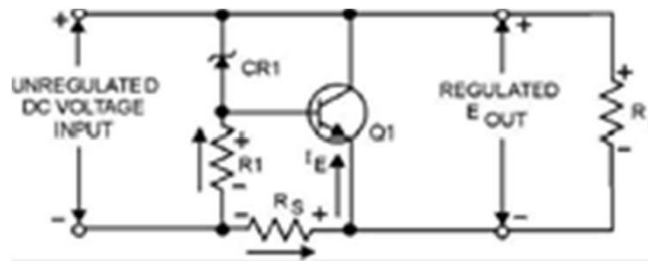

E7D06 (C)

What is the purpose of Q_1 in the circuit shown in Figure E7-3? **It increases the current-handling capability of the regulator**

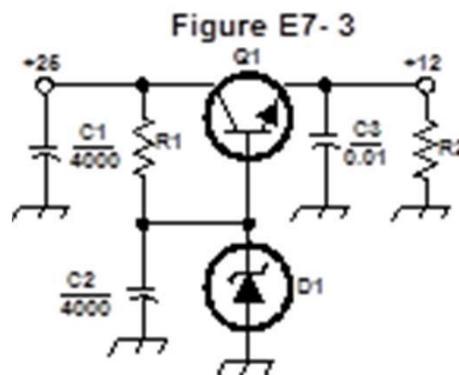

E7D07 (A)

What is the purpose of C2 in the circuit shown in Figure E7-3?

It bypasses hum around D1

E7D08 (C)

What type of circuit is shown in Figure E7-3? **Linear voltage regulator**

E7D09 (C)

What is the main reason to use a charge controller with a solar power system? **Prevention of battery damage due to overcharge**

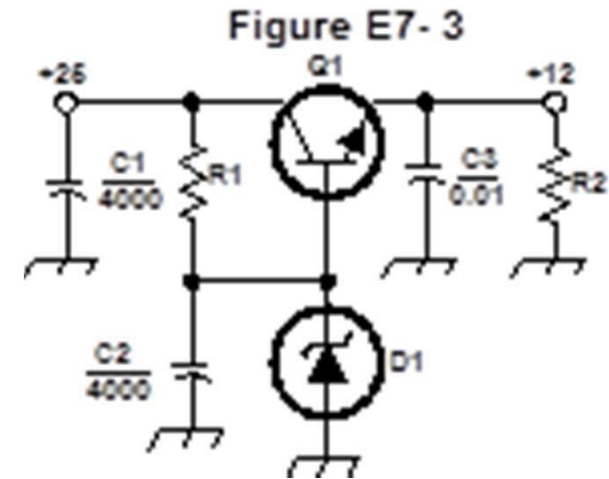

E7D10 (C)

What is the primary reason that a high-frequency switching type high voltage power supply can be both less expensive and lighter in weight than a conventional power supply? **The high frequency inverter design uses much smaller transformers and filter components for an equivalent power output**

E7D11 (D)

What circuit element is controlled by a series analog voltage regulator to maintain a constant output voltage? **Pass transistor**

E7D12 (C)

What is the drop-out voltage of an analog voltage regulator? **Minimum input-to-output voltage required to maintain regulation**

E7D13 (C)

What is the equation for calculating power dissipation by a series connected linear voltage regulator?

Voltage difference from input to output multiplied by output current

E7D10 (C)

What is the primary reason that a high-frequency switching type high voltage power supply can be both less expensive and lighter in weight than a conventional power supply? **The high frequency inverter design uses much smaller transformers and filter components for an equivalent power output**

E7D11 (D)

What circuit element is controlled by a series analog voltage regulator to maintain a constant output voltage? **Pass transistor**

E7D15 (D)

What is the purpose of a "step-start" circuit in a high voltage power supply? **To allow the filter capacitors to charge gradually**

E7D16 (D)

When several electrolytic filter capacitors are connected in series to increase the operating voltage of a power supply filter circuit, why should resistors be connected across each capacitor?

- A. To equalize, as much as possible, the voltage drop across each capacitor**
- B. To provide a safety bleeder to discharge the capacitors when the supply is off**
- C. To provide a minimum load current to reduce voltage excursions at light loads**
- D. All of these choices are correct**

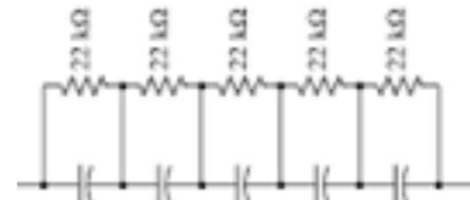

Element 7 Sub-Element E

E7E01 (B)

Which of the following can be used to generate FM phone emissions? **A reactance modulator on the oscillator**

A reactance modulator is a circuit that uses a transistor amplifier that acts like either a variable capacitor or an inductor. When the circuit is connected across the tuned circuit of an oscillator, the oscillator frequency can be varied by applying the modulating signal to the amplifier.

E7E02 (D)

What is the function of a reactance modulator? **To produce PM signals by using an electrically variable inductance or capacitance**

PM is Phase Modulation.

E7E03 (C)

How does an analog phase modulator function? **By varying the tuning of an amplifier tank circuit to produce PM signals**

E7E04 (A)

What is one way a single-sideband phone signal can be generated? **By using a balanced modulator followed by a filter**

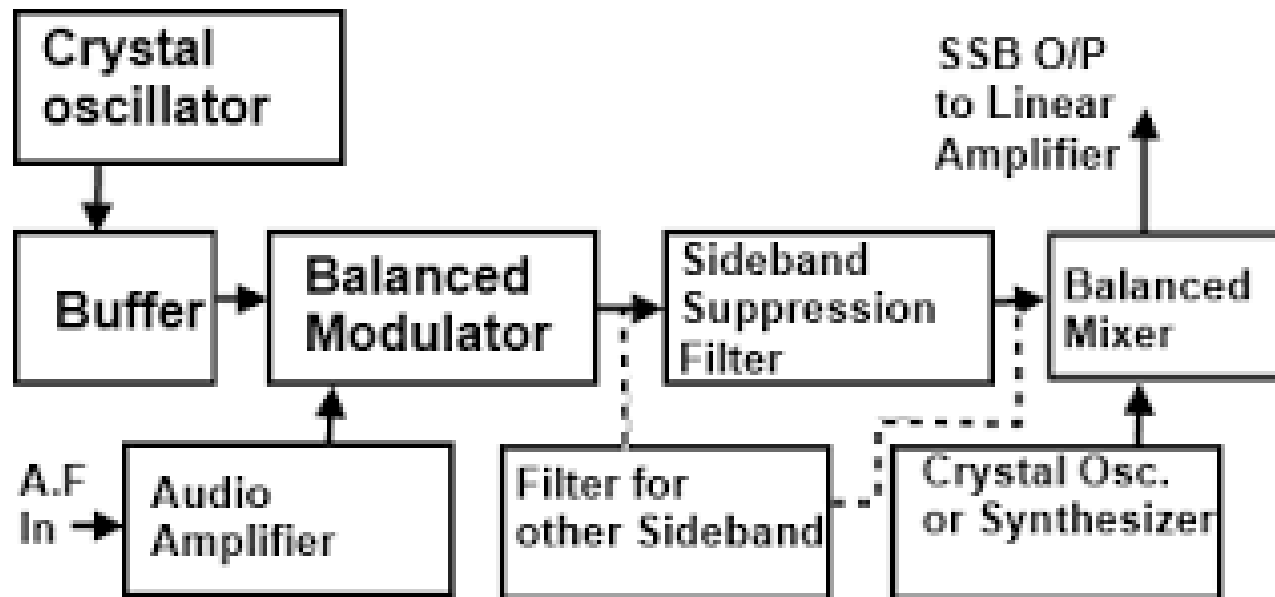

E7E05 (D)

What circuit is added to an FM transmitter to boost the higher audio frequencies? **A pre-emphasis network**

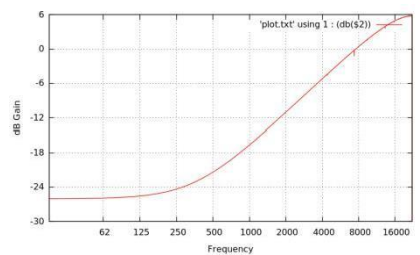

E7E06 (A)

Why is de-emphasis commonly used in FM communications receivers? **For compatibility with transmitters using phase modulation**

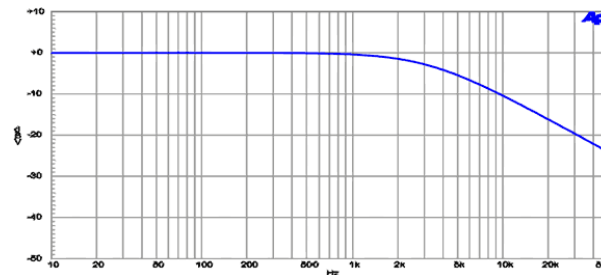

E7E07 (B)

What is meant by the term baseband in radio communications? **The frequency components present in the modulating signal**

E7E08 (C)

What are the principal frequencies that appear at the output of a mixer circuit? **The two input frequencies along with their sum and difference frequencies**

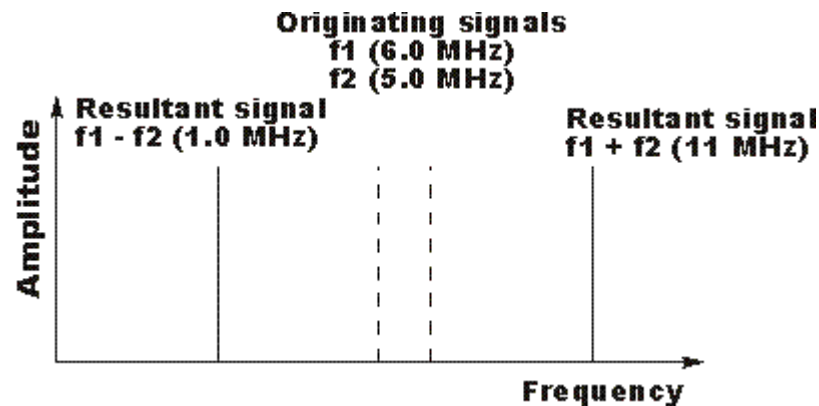

E7E09 (A)

What occurs when an excessive amount of signal energy reaches a mixer circuit? **Spurious mixer products are generated**

E7E10 (A)

How does a diode detector function? **By rectification and filtering of RF signals**

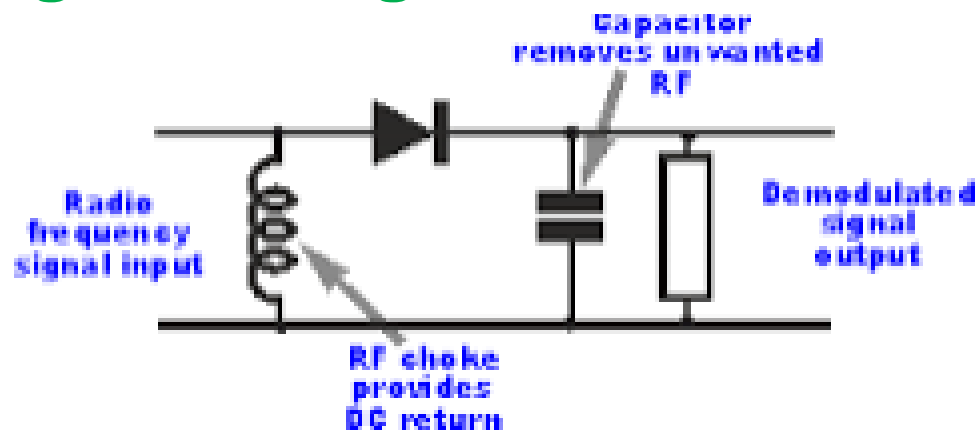

E7E11 (C)

Which type of detector is used for demodulating SSB signals?
Product detector

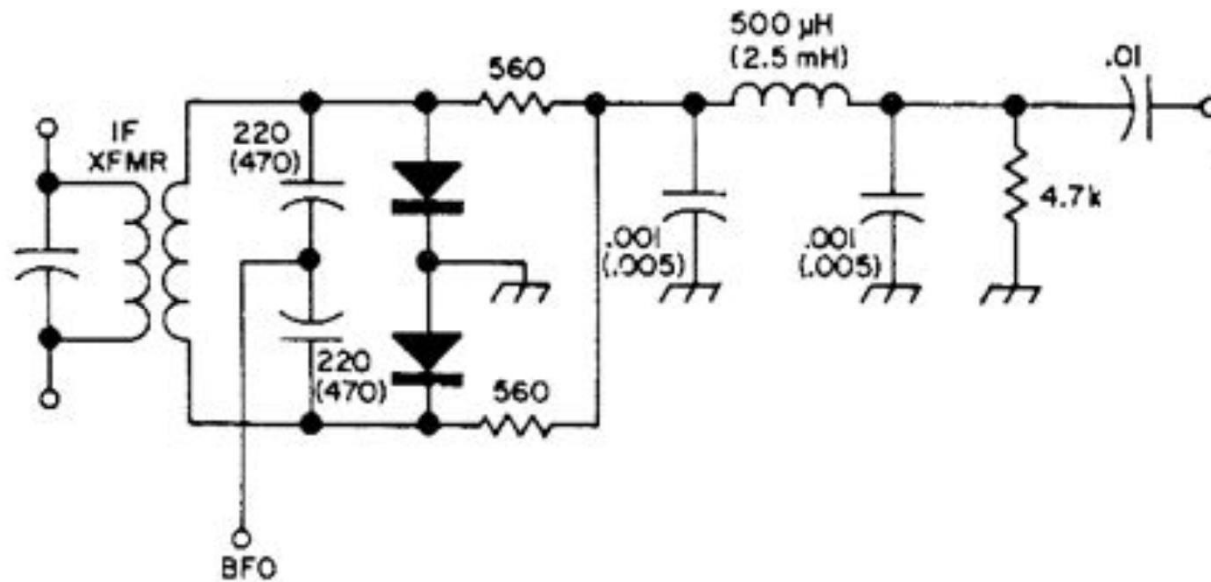

E7E12 (D)

What is a frequency discriminator stage in a FM receiver? **A circuit for detecting FM signals**

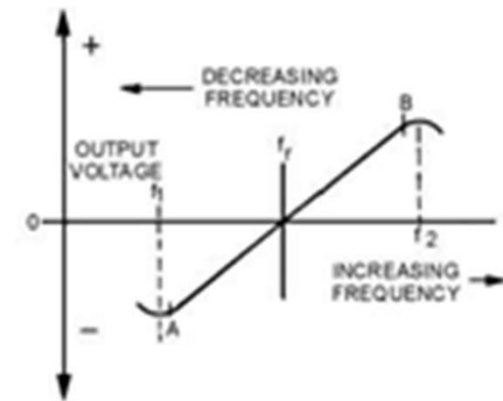
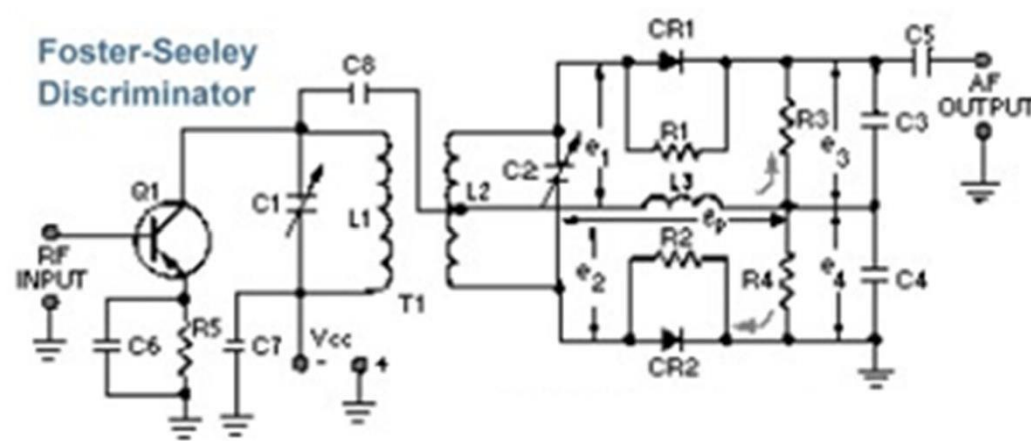

Element 7 Sub-Element F

E7F01 (C)

What is meant by direct digital conversion as applied to software defined radios? **Incoming RF is digitized by an analog-to-digital converter without being mixed with a local oscillator signal**

E7F02 (A)

What kind of digital signal processing audio filter is used to remove unwanted noise from a received SSB signal? **An adaptive filter**

An adaptive filter is a system with a linear filter that has a transfer function controlled by variable parameters and a means to adjust those parameters according to an optimization algorithm. Because of the complexity of the optimization algorithms, almost all adaptive filters are digital filters.

E7F03 (C)

What type of digital signal processing filter is used to generate an SSB signal? **A Hilbert-transform filter**

Digital Hilbert transform filters are a special class of digital filter whose characteristic is to introduce a $\pi/2$ radians phase shift of the input signal. In the ideal Hilbert transformer all the positive frequency components are shifted by $-\pi/2$ radians and all the negative frequency components are shifted by $+\pi/2$ radians. One radian = 57.2958 degrees.

E7F04 (D)

What is a common method of generating an SSB signal using digital signal processing? **Combine signals with a quadrature phase relationship**

E7F05 (B)

How frequently must an analog signal be sampled by an analog-to-digital converter so that the signal can be accurately reproduced? **At twice the rate of the highest frequency component of the signal**

E7F06 (D)

What is the minimum number of bits required for an analog-to-digital converter to sample a signal with a range of 1 volt at a resolution of 1 millivolt? **10 bits**

Resolution	One part in:
1 bit	2
2 bit	4
3 bit	8
4 bit	16
5bit	32
6 bit	64
7 bit	128
8bit	256
9 bit	512
10 bit	1028

E7F07 (C)

What function can a Fast Fourier Transform perform?

Converting digital signals from the time domain to the frequency domain

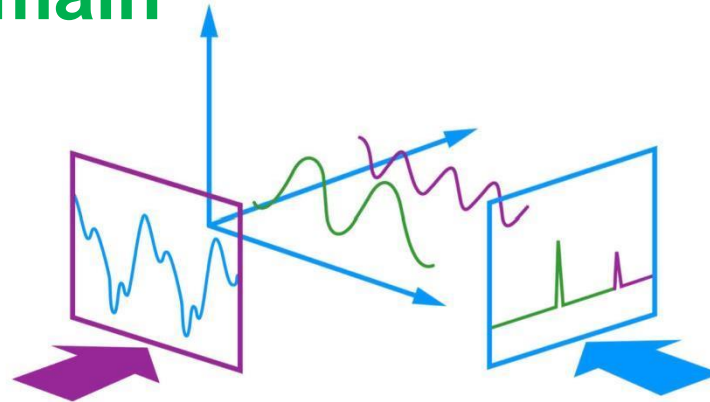

E7F08 (B)

What is the function of decimation with regard to digital filters?

Reducing the effective sample rate by removing samples

E7F09 (A)

Why is an anti-aliasing digital filter required in a digital decimator? **It removes high-frequency signal components which would otherwise be reproduced as lower frequency components**

E7F10 (A)

What aspect of receiver analog-to-digital conversion determines the maximum receive bandwidth of a Direct Digital Conversion SDR? **Sample rate**

E7F11 (B)

What sets the minimum detectable signal level for an SDR in the absence of atmospheric or thermal noise? **Reference voltage level and sample width in bits**

E7F12 (A)

What digital process is applied to I and Q signals in order to recover the baseband modulation information? **Fast Fourier Transform**

E7F13 (D)

What is the function of taps in a digital signal processing filter? **Provide incremental signal delays for filter algorithms**

E7F14 (B)

Which of the following would allow a digital signal processing filter to create a sharper filter response?
More taps

E7F15 (A)

Which of the following is an advantage of a Finite Impulse Response (FIR) filter vs an Infinite Impulse Response (IIR) digital filter? **FIR filters delay all frequency components of the signal by the same amount**

E7F16 (D)

How might the sampling rate of an existing digital signal be adjusted by a factor of 3/4? **Interpolate by a factor of three, then decimate by a factor of four**

Interpolation increases the original sampling rate of a sequence to a higher rate.

Decimation is the process of reducing the sampling rate. In practice, this usually implies low-pass-filtering a signal, then throwing away some of its samples.

E7F17 (D)

What do the letters I and Q in I/Q Modulation represent? **In-phase and Quadrature**

Quadrature means shifted by 90°

Element 7 Sub-Element G

Operational Amplifier Tutorial

An Operational Amplifier, or op-amp for short, is fundamentally a voltage amplifying device designed to be used with external feedback components such as resistors and capacitors between its output and input terminals. These feedback components determine the resulting function or “operation” of the amplifier and by virtue of the different feedback configurations whether resistive, capacitive or both, the amplifier can perform a variety of different operations, giving rise to its name of “Operational Amplifier”.

An Operational Amplifier is basically a three-terminal device which consists of two high impedance inputs, one called the Inverting Input, marked with a negative or “minus” sign, (-) and the other one called the Non-inverting Input, marked with a positive or “plus” sign (+). The output port which can both sink and source either a voltage or a current. In a linear operational amplifier, the output signal is the amplification factor, known as the amplifiers gain (A) multiplied by the value of the input signal and depending on the nature of these input and output signals, there can be four different classifications of operational amplifier gain.

Voltage -Voltage “in” and Voltage “out”

Current -Current “in” and Current “out”

Transconductance -Voltage “in” and Current “out”

Transresistance -Current “in” and Voltage “out”

An Operational Amplifier

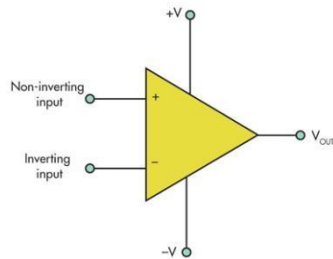

Op-amp Parameter and Idealised Characteristic

Open Loop Gain - Infinite
Input impedance - Infinite
Output impedance - Zero
Bandwidth, (BW) - Infinite
Offset Voltage - Zero

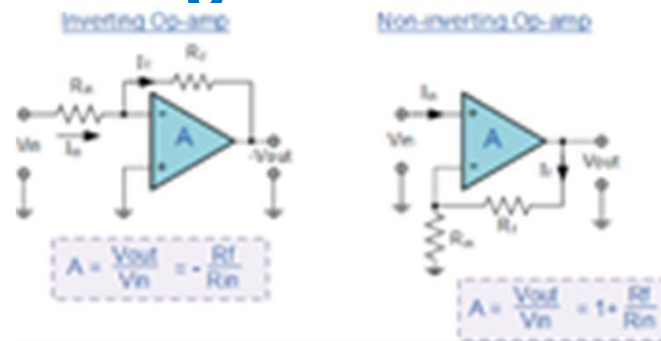

E7G01 (A)

What is the typical output impedance of an integrated circuit op-amp? **Very low**

E7G02 (D)

What is the effect of ringing in a filter? **Undesired oscillations added to the desired signal**

E7G03 (D)

What is the typical input impedance of an integrated circuit op-amp? **Very high**

E7G04 (C)

What is meant by the term op-amp input offset voltage? **The differential input voltage needed to bring the open loop output voltage to zero**

E7G05 (A)

How can unwanted ringing and audio instability be prevented in a multi-section op-amp RC audio filter circuit? **Restrict both gain and Q**

E7G06 (D)

Which of the following is the most appropriate use of an op-amp active filter **As an audio filter in a receiver**

E7G07 (C)

What magnitude of voltage gain can be expected from the circuit in Figure E7-4 when R1 is 10 ohms and RF is 470 ohms? **47**

$$\text{Gain} = R_F \div R_1 \text{ or Gain} = 470 \div 10 \text{ or gain} = 47$$

Figure E7-4

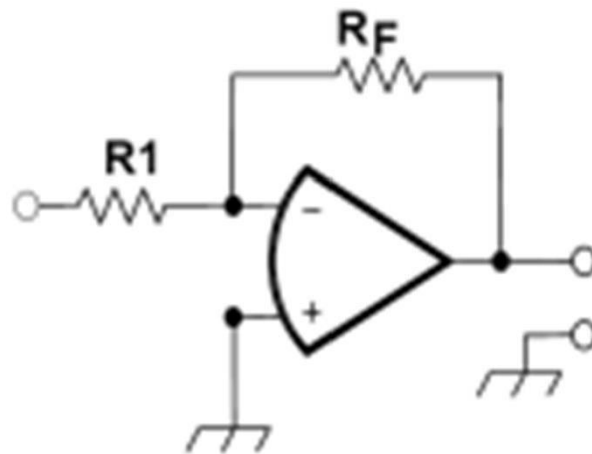

E7G08 (D)

How does the gain of an ideal operational amplifier vary with frequency? **It does not vary with frequency**

E7G09 (D)

What will be the output voltage of the circuit shown in Figure E7-4 if R1 is 1000 ohms, RF is 10,000 ohms, and + 0.23 volts DC is applied to the input? **-2.3 volts**

Gain = $RF \div R1$ or Gain = $10,000 \div 1000$ or gain = 10

Output is input multiplied by gain times -1* or Output = $0.23 \times 10 \times -1$ or -2.3 volt

**** the multiply by -1 comes from the fact that this an inverting configuration***

E7G10 (C)

What absolute voltage gain can be expected from the circuit in Figure E7-4 when R1 is 1800 ohms and RF is 68 kilohms? **38**

$$\text{Gain} = R_F \div R_1 \text{ or Gain} = 68000 \div 1800 \text{ or gain} = 37.77$$

E7G11 (B)

What absolute voltage gain can be expected from the circuit in Figure E7-4 when R1 is 3300 ohms and RF is 47 kilohms? **14**

$$\text{Gain} = R_F \div R_1 \text{ or Gain} = 47,000 \div 3,300 \text{ or gain} = 14$$

E7G12 (A)

What is an integrated circuit operational amplifier? **A**

high-gain, direct-coupled differential amplifier with very high input impedance and very low output impedance

Element 7 Sub-Element H

E7H01 (D)

What are three oscillator circuits used in Amateur Radio equipment? **Colpitts, Hartley and Pierce**

E7H02 (C)

Which describes a microphonic? **Changes in oscillator frequency due to mechanical vibration**

E7H03 (A)

How is positive feedback supplied in a Hartley oscillator? **Through a tapped coil**

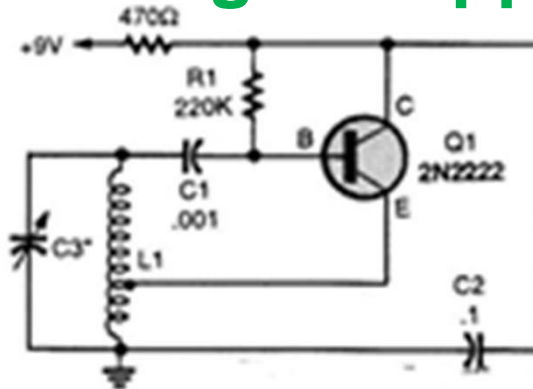

E7H04 (C)

How is positive feedback supplied in a Colpitts oscillator? **Through a capacitive divider**

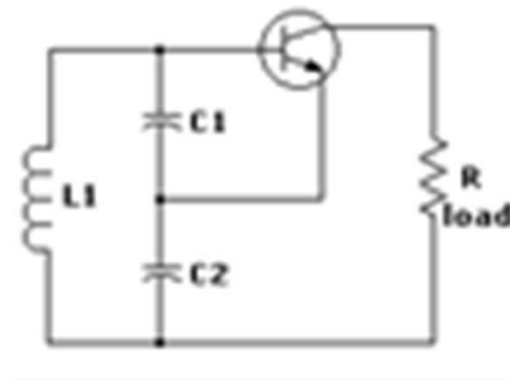

E7H05 (D)

How is positive feedback supplied in a Pierce oscillator?

Through a quartz crystal

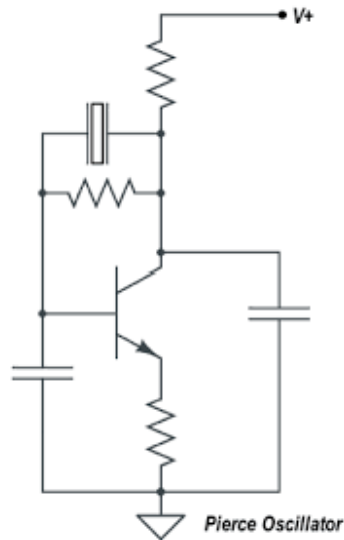

E7H06 (B)

Which of the following oscillator circuits are commonly used in VFOs? **Colpitts and Hartley**

E7H07 (D)

How can an oscillator's microphonic responses be reduced? **Mechanically isolating the oscillator circuitry from its enclosure**

E7H08 (A)

Which of the following components can be used to reduce thermal drift in crystal oscillators? **NPO capacitors**

NPO stands for negative-positive 0 ppm/°C, meaning that for negative or positive shifts in temperature, the capacitance changes 0 part per million, meaning that it has a constant value across a wide range of temperatures; the capacitance value of the NPO capacitor stays constant despite variations in temperature.

E7H09 (A)

What type of frequency synthesizer circuit uses a phase accumulator, lookup table, digital to analog converter, and a low-pass anti-alias filter? **A direct digital synthesizer**

E7H10 (B)

What information is contained in the lookup table of a direct digital frequency synthesizer? **The amplitude values that represent a sine-wave output**

E7H11 (C)

What are the major spectral impurity components of direct digital synthesizers? **Spurious signals at discrete frequencies**

E7H12 (B)

Which of the following must be done to insure that a crystal oscillator provides the frequency specified by the crystal manufacturer? **Provide the crystal with a specified parallel capacitance**

Since the circuit the crystal is installed in has capacitance it will affect the crystal frequency if the crystal is not manufactured with that parallel capacitance in mind.

E7H13 (D)

Which of the following is a technique for providing highly accurate and stable oscillators needed for microwave transmission and reception?

A. Use a GPS signal reference

B. Use a rubidium stabilized reference oscillator

C. Use a temperature-controlled high Q dielectric resonator

D. All of these choices are correct

E7H14 (C)

What is a phase-locked loop circuit? **An electronic servo loop consisting of a phase detector, a low-pass filter, a voltage-controlled oscillator, and a stable reference oscillator**

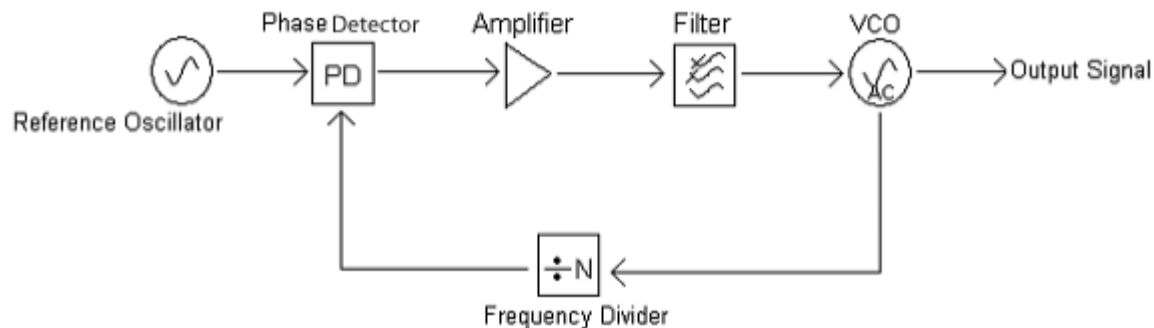

E7H15 (D)

Which of these functions can be performed by a phase-locked loop? **Frequency synthesis, FM demodulation**

ELEMENT E8
SIGNALS AND EMISSIONS
[4 Exam Questions - 4 Groups]

Element 8 Sub-Element A

E8A01 (A)

What is the name of the process that shows that a square wave is made up of a sine wave plus all of its odd harmonics? **Fourier analysis**

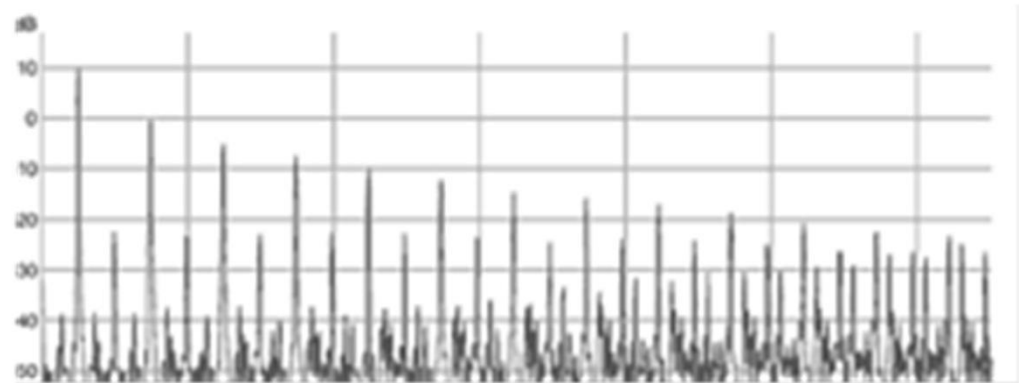
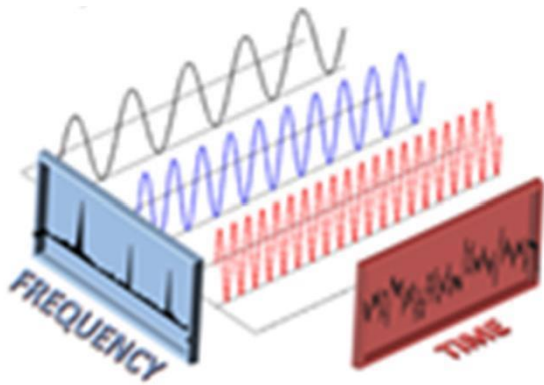

E8A02 (C)

What type of wave has a rise time significantly faster than its fall time (or vice versa)? **A sawtooth wave**



E8A03 (A)

What type of wave does a Fourier analysis show to be made up of sine waves of a given fundamental frequency plus all of its harmonics? **A sawtooth wave**

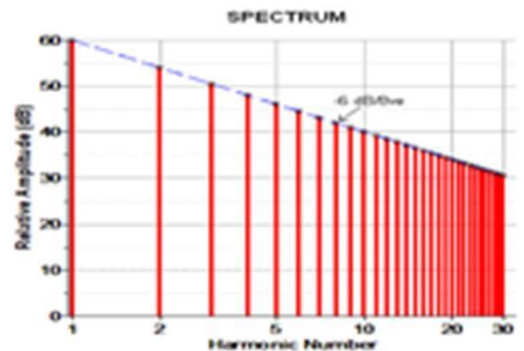

E8A04 (B)

What is "dither" with respect to analog to digital converters? **A small amount of noise added to the input signal to allow more precise representation of a signal over time**

E8A05 (D)

What would be the most accurate way of measuring the RMS voltage of a complex waveform? **By measuring the heating effect in a known resistor**

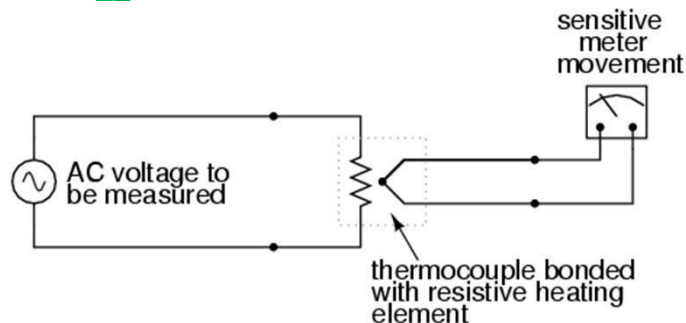

E8A06 (A)

What is the approximate ratio of PEP-to-average power in a typical single-sideband phone signal? **2.5 to 1**

PEP is Peak Envelope Power

E8A07 (B)

What determines the PEP-to-average power ratio of a single-sideband phone signal? **The characteristics of the modulating signal**

Speech processing can be used to change the average to peak power ratio of a SSB signal

E8A08 (C)

Why would a direct or flash conversion analog-to-digital converter be useful for a software defined radio?

Very high speed allows digitizing high frequencies

E8A09 (D)

How many levels can an analog-to-digital converter with 8 bit resolution encode? **256**

Bit	Resolution
1	2
2	4
3	8
4	16
5	32
6	64
7	128
8	256

E8A10 (C)

What is the purpose of a low pass filter used in conjunction with a digital-to-analog converter? **Remove harmonics from the output caused by the discrete analog levels generated**

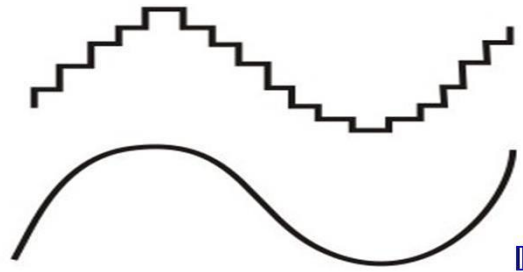

E8A11 (D)

What type of information can be conveyed using digital waveforms?

A. Human speech

B. Video signals

C. Data

D. All of these choices are correct

E8A12 (C)

What is an advantage of using digital signals instead of analog signals to convey the same information?

Digital signals can be regenerated multiple times without error

E8A13 (A)

Which of these methods is commonly used to convert analog signals to digital signals? **Sequential sampling**

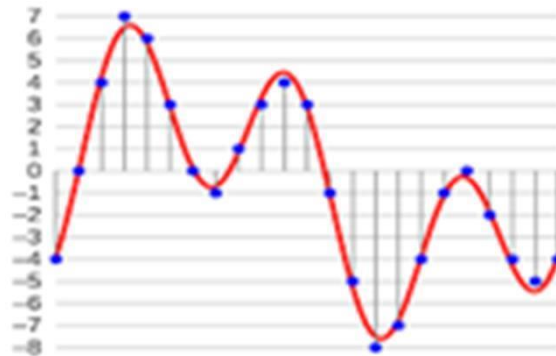

Element 8 Sub-Element B

E8B01 (D)

What is the term for the ratio between the frequency deviation of an RF carrier wave and the modulating frequency of its corresponding FM-phone signal?

Modulation index

$$\text{Modulation index} = \Delta f \div f_m$$

Where Δf = frequency deviation and f_m = modulation frequency

-

E8B02 (D)

How does the modulation index of a phase-modulated emission vary with RF carrier frequency (the modulated frequency)? **It does not depend on the RF carrier frequency**

Modulation index is only dependent on the frequency deviation and the modulating frequency (see answer to E8B01).

E8B03 (A)

What is the modulation index of an FM-phone signal having a maximum frequency deviation of 3000 Hz either side of the carrier frequency when the modulating frequency is 1000 Hz? **3**

$$\text{Modulation index} = \Delta f \div f_m \text{ or}$$

$$\text{Modulation index} = 3,000 \div 1,000 \text{ or } 3$$

E8B04 (B)

What is the modulation index of an FM-phone signal having a maximum carrier deviation of plus or minus 6 kHz when modulated with a 2 kHz modulating frequency? **3**

*Modulation Index = $\Delta f \div fm$ or Modulation index or
 $6,000 \div 2,000$ or 3*

E8B05 (D)

What is the deviation ratio of an FM-phone signal having a maximum frequency swing of plus-or-minus 5 kHz when the maximum modulation frequency is 3 kHz? **1.67**

*deviation ratio = maximum deviation \div maximum
modulation frequency or $5 \div 3$ or 1.67*

E8B06 (A)

What is the deviation ratio of an FM-phone signal having a maximum frequency swing of plus or minus 7.5 kHz when the maximum modulation frequency is 3.5 kHz? **2.14**

deviation ratio = max deviation ÷ max modulation frequency or 7.5 ÷ 3.5 or 2.14

E8B07 (A)

Orthogonal Frequency Division Multiplexing is a technique used for which type of amateur communication? **High speed digital modes**

Orthogonal Frequency Division Multiplexing (OFDM) is a method of encoding digital data on multiple carrier frequencies.

E8B08 (D)

What describes Orthogonal Frequency Division Multiplexing? **A digital modulation technique using subcarriers at frequencies chosen to avoid intersymbol interference**

OFDM is a frequency division multiplexing (FDM) scheme used as a digital multi-carrier modulation method. A large number of closely spaced orthogonal sub carrier signals are used to carry data on several parallel data streams or channels. Each sub-carrier is modulated with a conventional modulation scheme (such as quadrature amplitude modulation or phase-shift at a low symbol, maintaining total data rates similar to conventional single-carrier modulation schemes in the same bandwidth.

E8B09 (B)

What is meant by deviation ratio? **The ratio of the maximum carrier frequency deviation to the highest audio modulating frequency**

$$\text{deviation ratio} = \text{max deviation} \div \text{max modulation frequency}$$

E8B10 (B)

What describes frequency division multiplexing? **Two or more information streams are merged into a baseband, which then modulates the transmitter**



E8B11 (B)

What is digital time division multiplexing? **Two or more signals are arranged to share discrete time slots of a data transmission**

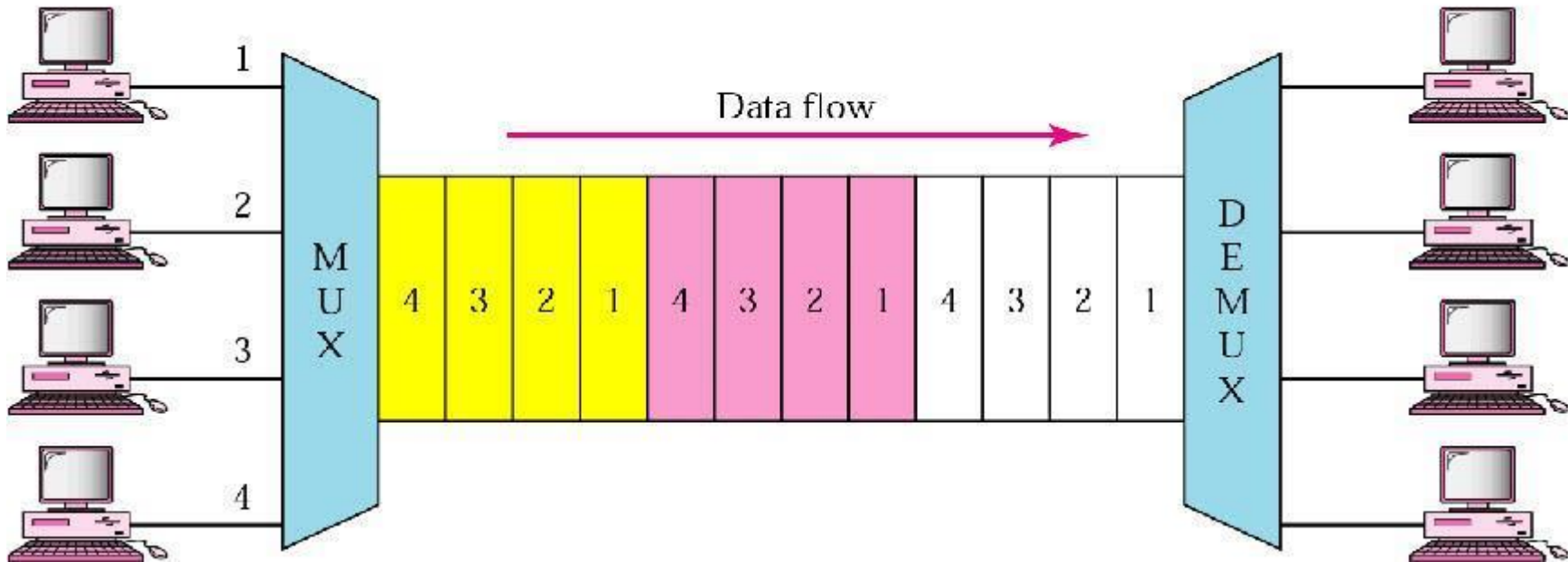

Element 8 Sub-Element C

E8C01 (C)

How is Forward Error Correction implemented? **By transmitting extra data that may be used to detect and correct transmission errors**

Forward error correction (FEC) is a digital signal processing technique used to enhance data reliability. It does this by introducing redundant data, called error correcting code, prior to data transmission or storage. FEC provides the receiver with the ability to correct errors without a reverse channel to request the retransmission of data.

E8C02 (C)

What is the definition of symbol rate in a digital transmission? **The rate at which the waveform of a transmitted signal changes to convey information**

In digital communications, symbol rate, also known as baud rate and modulation rate, is the number of symbol changes, waveform changes, or signaling events, across the transmission medium per time unit using a digitally modulated signal. The symbol rate is measured in baud or symbols per second.

E8C03 (A)

When performing phase shift keying, why is it advantageous to shift phase precisely at the zero crossing of the RF carrier? **This results in the least possible transmitted bandwidth for the particular mode**

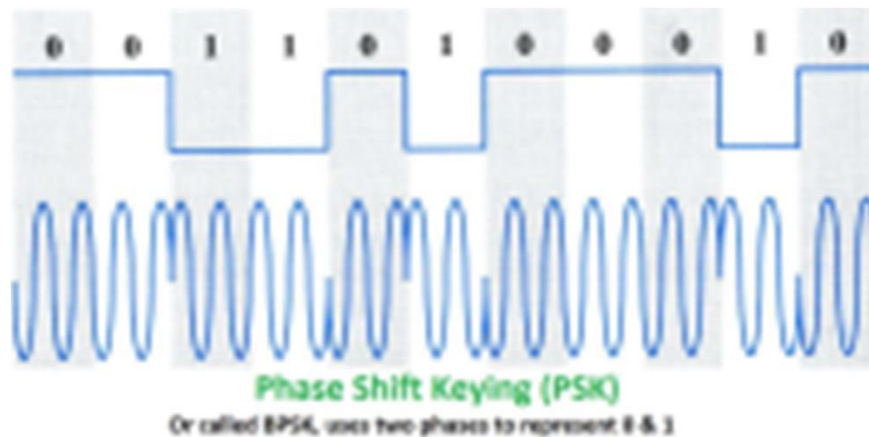

E8C04 (C)

What technique is used to minimize the bandwidth requirements of a PSK31 signal? **Use of sinusoidal data**

pulses

PSK31 or "Phase Shift Keying, 31 Baud " is a popular computer soundcard -generated radio teletype mode, used primarily by amateur radio operators to conduct real-time keyboard-to-keyboard chat, most often using frequencies in the HF amateur radio bands. PSK31 is distinguished from other digital modes in that it is specifically tuned to have a data rate close to typing speed, and has an extremely narrow bandwidth, allowing many conversations in the same bandwidth as a single voice channel. This narrow bandwidth also concentrates the RF energy in a very narrow bandwidth , allowing relatively low-power equipment to communicate globally using the same Skywave propagation used by DX stations.

E8C05 (C)

What is the necessary bandwidth of a 13-WPM international Morse code transmission? **Approximately 52 Hz**

E8C06 (C)

What is the necessary bandwidth of a 170-hertz shift, 300-baud ASCII transmission? **0.5 kHz**

The bandwidth of the signal depends on the frequency shift used and the speed the data is transmitted.

The formula is: $BW = (K \times \text{Shift}) + B$ Where: BW is the bandwidth; K is a constant that depends on allowable distortion. 1.2 is practical for amateur communications, Shift is the frequency shift in Hz and B is the symbol rate in

~~baud~~ $BW = (1.2 \times 170 \text{ Hz}) + 300$ or $204 = 300$ or 504Hz or 0.504 KHz

E8C07 (A)

What is the necessary bandwidth of a 4800-Hz frequency shift, 9600-baud ASCII FM transmission?

15.36 kHz

Again using the equation in E8C06:

$$BW = (1.2 \times 4800 \text{ Hz}) + 9600 \text{ or } 5760 + 9600 \text{ or } 15.36 \text{ KHz}$$

E8C08 (D)

How does ARQ accomplish error correction? **If errors are detected, a retransmission is requested**

Automatic Repeat request (ARQ), also known as Automatic Repeat Query, is an error control method for data transmission that uses acknowledgements (messages sent by the receiver indicating that it has correctly received a data frame or packet) and timeouts (specified periods of time allowed to elapse before an acknowledgment is to be received) to achieve reliable data transmission over an unreliable path. If the sender does not receive an acknowledgment before the timeout, it usually re-transmits the frame/packet until the sender receives an acknowledgment or exceeds a predefined number of re-transmissions.

E8C09 (D)

Which is the name of a digital code where each preceding or following character changes by only one bit? **Gray code**

Gray code is a binary numeral system where two successive values differ in only one bit (binary digit). Today, Gray codes are widely used to facilitate error correction in digital communications such as digital terrestrial television and some cable TV systems.

E8C10 (D)

What is an advantage of Gray code in digital communications where symbols are transmitted as multiple bits **It facilitates error detection**

E8C11 (A)

What is the relationship between symbol rate and baud?

They are the same

The speed of a data stream is expressed in bits per second (bits/s or bps). The data rate is a function of the duration of the bit or bit time

Baud rate refers to the number of signal or symbol changes that occur per second. A symbol is one of several voltage, frequency, or phase changes.

NRZ (Non Return to Zero) binary has two symbols, one for each bit 0 or 1, that represent voltage levels. In this case, the baud or symbol rate is the same as the bit rate. However, it's possible to have more than two symbols per transmission interval, whereby each symbol represents multiple bits.

Quadrature Phase Shift Keying (QPSK) example where one symbol change can represent one of 4 values:

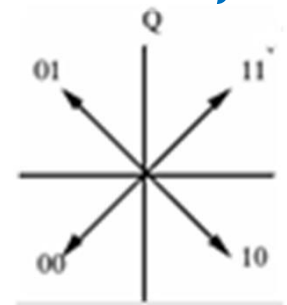

Element 8 Sub-Element D

E8D01 (A)

Why are received spread spectrum signals resistant to interference? **Signals not using the spread spectrum algorithm are suppressed in the receiver**

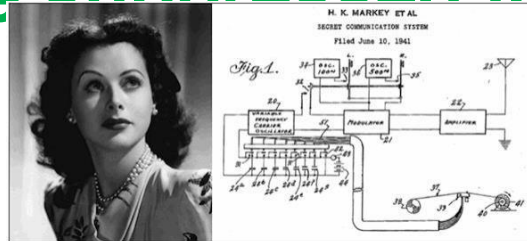

At the beginning of world war II Hedy Lamarr and her Husband developed a radio guidance system for Allied torpedoes which used Frequency hopping technology to defeat the threat of jamming by the Axis powers. Though the US Navy did not adopt the technology until the 1960s, the principles of their work are now incorporated into modern communication technologies and this work led to their being inducted into the National Inventors Hall of Fame in 2014

E8D02 (B)

What spread spectrum communications technique uses a high speed binary bit stream to shift the phase of an RF carrier? **Direct sequence**

Spread spectrum systems are such that they transmit the message bearing signals using a bandwidth that is in excess of the bandwidth that is actually needed by the message signal. This spreading of the transmitted signal over a large bandwidth makes the resulting wideband signal appear as a noise signal, which allows greater resistance to intentional and unintentional interference with the transmitted signal.

E8D04 (C)

What is the primary effect of extremely short rise or fall time on a CW signal? **The generation of key clicks**

E8D05 (A)

What is the most common method of reducing key clicks? **Increase keying waveform rise and fall times**

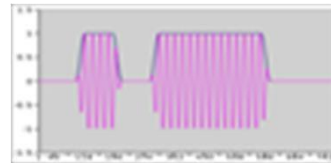
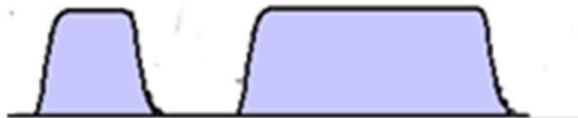

E8D06 (B)

Which of the following indicates likely overmodulation of an AFSK signal such as PSK or MFSK? **Strong ALC action**

AFSK is Amplitude Frequency Shift Keying, PSK is Phase Shift Keying, and MFSK is Multiple Frequency Shift Keying.

E8D07 (D)

What is a common cause of over modulation of AFSK signals? **Excessive transmit audio levels**

E8D08 (D)

What parameter might indicate that excessively high input levels are causing distortion in an AFSK signal?

Intermodulation Distortion (IMD)

E8D09 (D)

What is considered a good minimum IMD level for an idling PSK signal? **-30 dB**

IMD is Intermodulation Distortion

E8D10 (B)

What are some of the differences between the Baudot digital code and ASCII? **Baudot uses 5 data bits per character, ASCII uses 7 or 8; Baudot uses 2 characters as letters/figures shift codes, ASCII has no letters/figures shift code**

ASCII code allows the transmission of both upper and lower case characters without using special shift codes. ASCII stands for American Standard Code for Information Interchange. ASCII code is a numerical representation of a character such as 'a', 'A' '@' or an action of some sort. Baudot only supports upper case letters.

E8D11 (C)

What is one advantage of using ASCII code for data communications? **It is possible to transmit both upper and lower case text**

E8D12 (D)

What is the advantage of including a parity bit with an ASCII character stream? **Some types of errors can be detected**

Original Data	Even Parity	Odd Parity
00000000	0	1
01011011	1	0
01010101	0	1
11111111	0	1
10000000	1	0
01001001	1	0

ELEMENT E9
ANTENNAS AND TRANSMISSION
LINES

[8 Exam Questions - 8 Groups]

Element 9 Sub-Element A

E9A01 (C)

What describes an isotropic antenna? **A theoretical antenna used as a reference for antenna gain**

E9A02 (D)

What antenna has no gain in any direction? **Isotropic antenna**

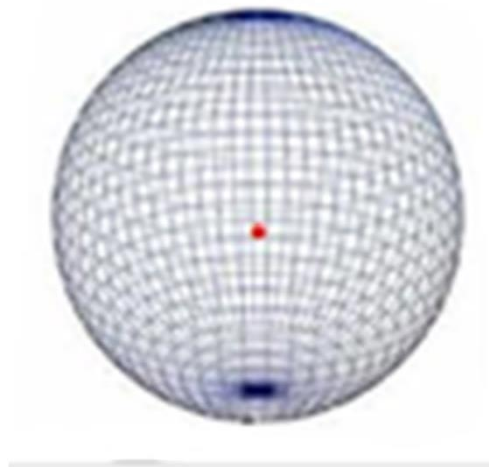

VSWR Tutorial

The term VSWR (Voltage Standing Wave Ratio) frequently referred to as SWR. VSWR and SWR refer to the same thing and are used interchangeably.

When we connect a transmitter to an antenna we want all the power to reach the antenna and all the power arriving at the antenna to be radiated as an electromagnetic wave. When antennas and transmission lines are not perfectly matched (exactly the same impedance as the transmitter) and some of the power we send to the antenna gets reflected back to the transmitter. The ratio of the power flowing to the antenna to the power reflected is VSWR. If we were to cut a slot in the transmission line we were feeding the antenna with we would see a peak and valley in the RF voltage on the center conductor occurring every quarter wavelength. VSWR is simply the maximum voltage on the transmission line divided by the minimum voltage on the transmission line.

If the maximum voltage was 1 volt and the minimum voltage was 0.80 volts the VSWR would be $1.00 \div 0.80$ or 1.25. When we state the VSWR we always relate it to one so we would say we have a VSWR of 1.25 : 1.

There are additional ways to express the mismatch between the Transmitter and antenna. They are:

- 1. Reflection Coefficient and Return Loss. Reflection coefficient is the $VSWR-1$ divided by the $VSWR+1$ or in the above example Reflection coefficient would be $(1.25 - 1) \div (1.25 + 1)$ **or** $0.25 \div 2.25$ **or** 0.11. The lower the reflection coefficient, the better the match is between the transmitter and the transmission line and the antenna.*

2. Return loss is simply the amount of power being returned from the Transmission line and the antenna to the transmitter expressed in dB relative to the forward power. A poor match would be a low dB number indicating there is little loss between the transmitted power and the reflected power. A higher number would indicate more loss between the transmitter and the antenna and the forward power therefore the antenna was radiating the power more efficiently.

There is a table showing the relationship between VSWR, Reflection Coefficient and Return Loss in the appendix.

E9A03 (A)

Why would one need to know the feed point impedance of an antenna? **To match impedances in order to minimize standing wave ratio on the transmission line**

When the feed point impedance of the antenna is matched to the transmitter and transmission line impedance you achieve maximum power transfer from the transmitter to the antenna.

E9A04 (B)

Which of the following factors may affect the feed point impedance of an antenna? **Antenna height, conductor length / diameter ratio and location of nearby conductive objects**

E9A05 (D)

What is included in the total resistance of an antenna system? **Radiation resistance plus ohmic resistance**

E9A06 (D)

How does the beamwidth of an antenna vary as the gain is increased? **It decreases**

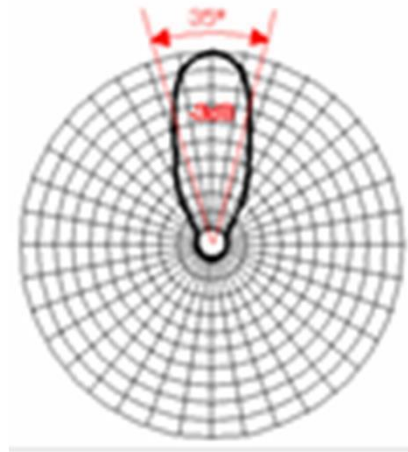

E9A07 (A)

What is meant by antenna gain? **The ratio of the radiated signal strength of an antenna in the direction of maximum radiation to that of a reference antenna**

What is meant by antenna bandwidth? **The frequency range over which an antenna satisfies a performance requirement**

E9A09 (B)

How is antenna efficiency calculated? **(radiation resistance / total resistance) x 100 per cent**

E9A10 (A)

Which of the following choices is a way to improve the efficiency of a ground-mounted quarter-wave vertical antenna? **Install a good radial system**

E9A11 (C)

Which of the following factors determines ground losses for a ground-mounted vertical antenna operating in the 3 MHz to 30 MHz range? **Soil conductivity**

E9A12 (A)

How much gain does an antenna have compared to a 1/2-wavelength dipole when it has 6 dB gain over an isotropic antenna? **3.85 dB**

dBd (dipole gain over an Isotropic antenna) - 2.15 dB

6dB-2.15dB or 3.85dB

E9A13 (B)

How much gain does an antenna have compared to a 1/2-wavelength dipole when it has 12 dB gain over an isotropic antenna? **9.85 dB**

dBd = dBi -2.15 dB or 12dBi -2.15dB or 9.85dB

E9A14 (C)

What is meant by the radiation resistance of an antenna? **The value of a resistance that would dissipate the same amount of power as that radiated from an antenna**

E9A15 (D)

What is the effective radiated power relative to a dipole of a repeater station with 150 watts transmitter power output, 2 dB feed line loss, 2.2 dB duplexer loss, and 7 dBd antenna gain? **286 watts**

150 watts - (-2dB -2.2 dB +7dB) or 150 watts + 2.8 dB
2.8 dB = 10log (P/ 150 watts) or ((2.8÷10) ^ (0.28) x (P/150)) or P=1.90 x 150 or P=285.8 Watts

E9A16 (A)

What is the effective radiated power relative to a dipole of a repeater station with 200 watts transmitter power output, 4 dB feed line loss, 3.2 dB duplexer loss, 0.8 dB circulator loss, and 10 dBd antenna gain? **317 watts**

200 watts (-4dB - 3.2dB - 0.8dB + 10dB) or 200 watts + 2 dB

2 dB = 10log (P/ 200 watts) or ((2 ÷ 10) ^0.28) x (P/200) or P=1.58 x 200 or P=316.9 Watts

E9A17 (B)

What is the effective radiated power of a repeater station with 200 watts transmitter power output, 2 dB feed line loss, 2.8 dB duplexer loss, 1.2 dB circulator loss, and 7 dBi antenna gain? **252 watts**

200 watts (-2dB -2.8dB -1.2dB +7dB) or 200 watts + 1 dB

1 dB = 10log (P/ 200 watts) or ((1÷10) ^0.28) x (P/200) or P=1.25 x 200 or P=251.7 Watts

E9A18 (C)

What term describes station output, taking into account all gains and losses? **Effective radiated power**

Element 9 Sub-Element B

E9B01 (B)

In the antenna radiation pattern shown in Figure E9-1, what is the 3 dB beam-width? **25 degrees**

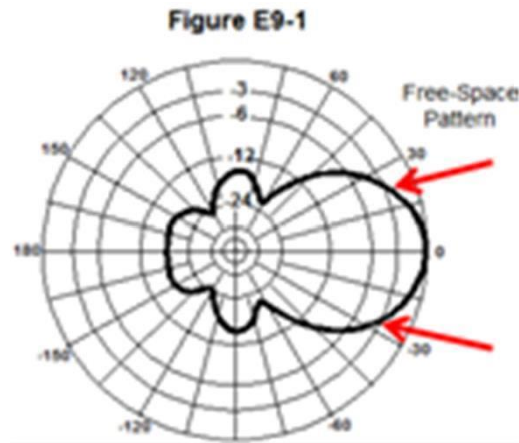

E9B02 (B)

In the antenna radiation pattern shown in Figure E9-1, what is the front-to-back ratio? **18 dB**

E9B03 (B)

In the antenna radiation pattern shown in Figure E9-1, what is the front-to-side ratio? **14 dB**

E9B04 (D)

What may occur when a directional antenna is operated at different frequencies within the band for which it was designed? **The gain may change depending on frequency**

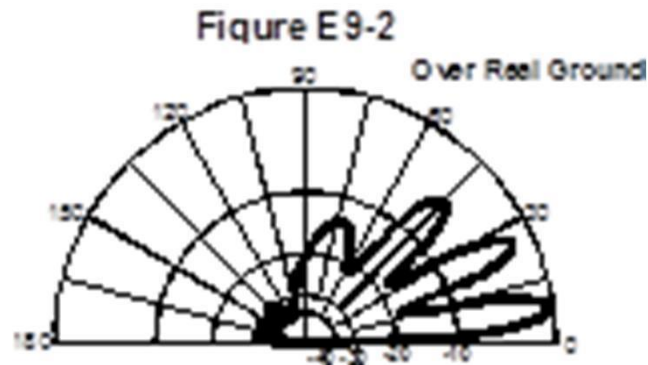

E9B05 (A)

What type of antenna pattern over real ground is shown in Figure E9-2? **Elevation**

E9B06 (C)

What is the elevation angle of peak response in the antenna radiation pattern shown in Figure E9-2? **7.5 degrees**

E9B07 (C)

How does the total amount of radiation emitted by a directional gain antenna compare with the total amount of radiation emitted from an isotropic antenna, assuming each is driven by the same amount of power?

They are the same

E9B08 (A)

How can the approximate beam-width in a given plane of a directional antenna be determined? **Note the two points where the signal strength of the antenna is 3 dB less than maximum and compute the angular difference**

E9B09 (B)

What type of computer program technique is commonly used for modeling antennas? **Method of Moments**

E9B10 (A)

What is the principle of a Method of Moments analysis? **A wire is modeled as a series of segments, each having a uniform value of current**

E9B11 (C)

What is a disadvantage of decreasing the number of wire segments in an antenna model below the guideline of 10 segments per half-wavelength? **The computed feed point impedance may be incorrect**

E9B12 (D)

What is the far field of an antenna? **The region where the shape of the antenna pattern is independent of distance**

E9B13 (B)

What does the abbreviation NEC stand for when applied to antenna modeling programs? **Numerical Electromagnetic Code**

E9B14 (D)

What type of information can be obtained by submitting the details of a proposed new antenna to a modeling program?

A. SWR vs frequency charts

B. Polar plots of the far field elevation and azimuth patterns

C. Antenna gain

D. All of these choices are correct

E9B15 (B)

What is the front-to-back ratio of the radiation pattern shown in Figure E9-2? **28 dB**

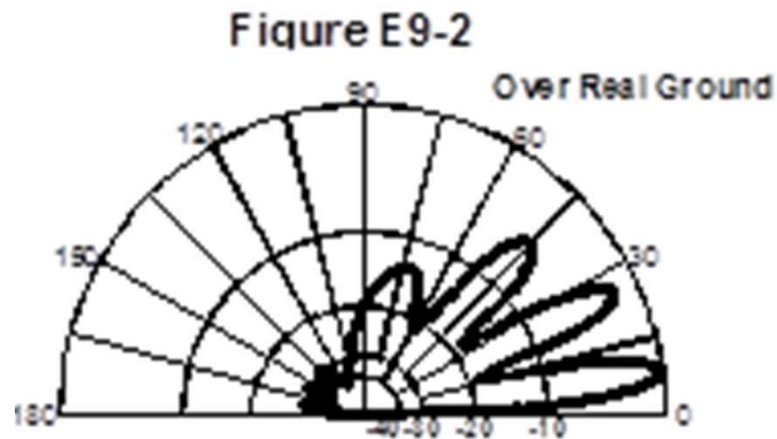

E9B16 (A)

How many elevation lobes appear in the forward direction of the antenna radiation pattern shown in Figure E9-2? **4**

Element 9 Sub-Element C

E9C01 (D)

What is the radiation pattern of two $1/4$ -wavelength vertical antennas spaced $1/2$ -wavelength apart and fed 180 degrees out of phase? **A figure-8 oriented along the axis of the array**

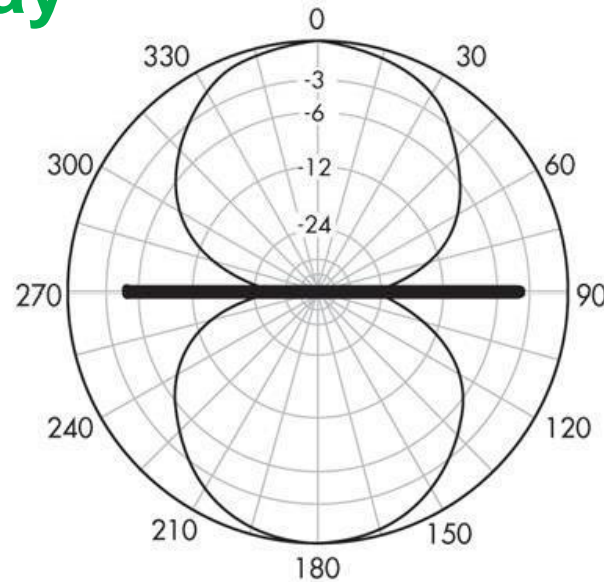

E9C02 (A)

What is the radiation pattern of two $1/4$ wavelength vertical antennas spaced $1/4$ wavelength apart and fed 90 degrees out of phase? **Cardioid**

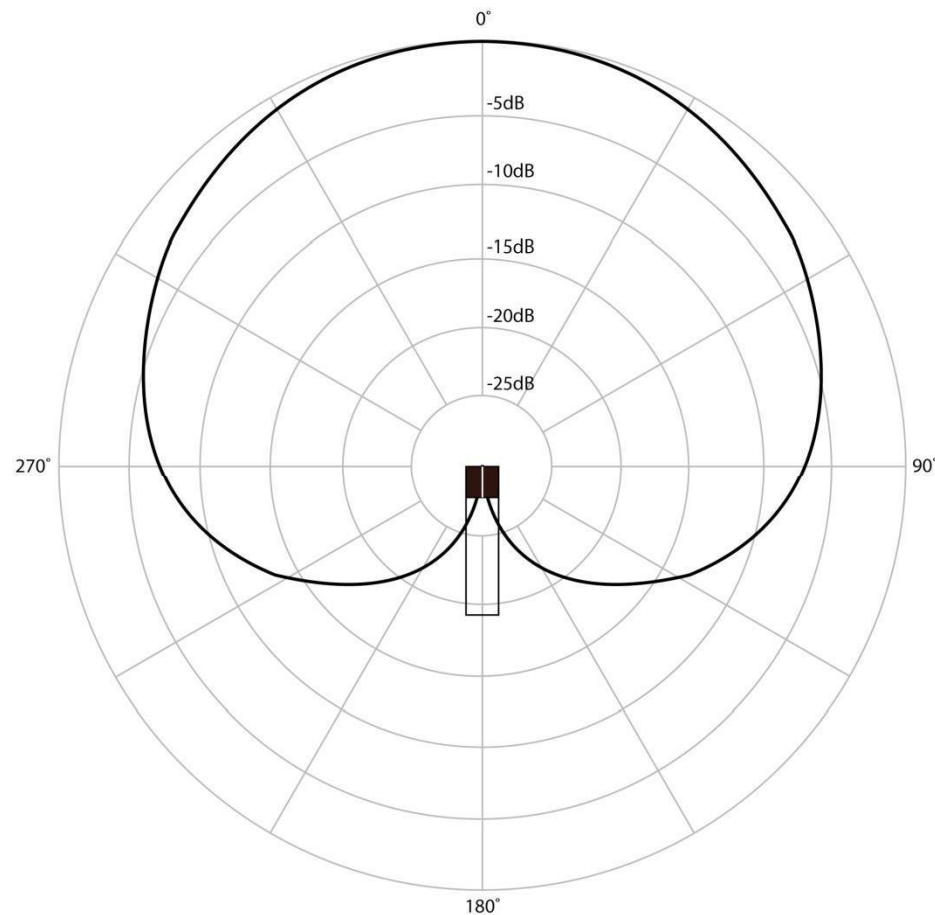

E9C03 (C)

What is the radiation pattern of two $1/4$ wavelength vertical antennas spaced a $1/2$ wavelength apart and fed in phase? **A Figure-8 broadside to the axis of the array**

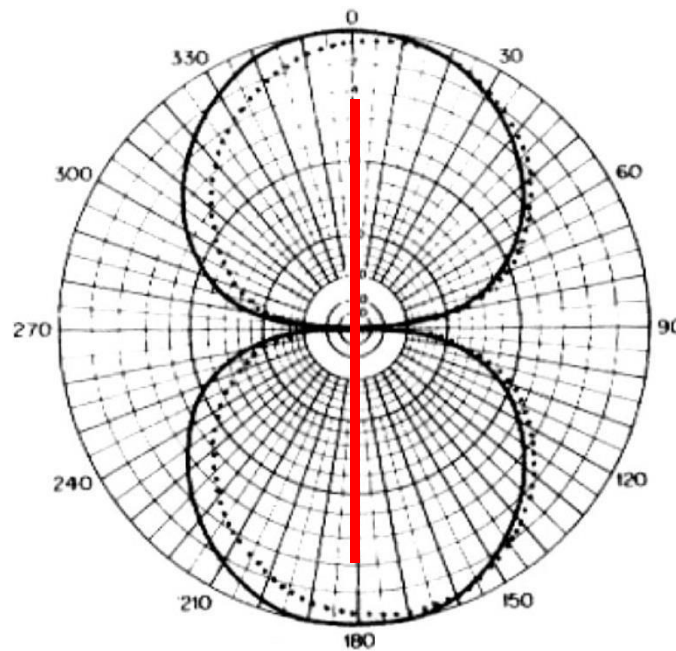

E9C04 (B)

What happens to the radiation pattern of an unterminated long wire antenna as the wire length is increased? **The lobes align more in the direction of the wire**

E9C05 (A)

What is an OCFD antenna? **A dipole feed approximately 1/3 the way from one end with a 4:1 balun to provide multiband operation**

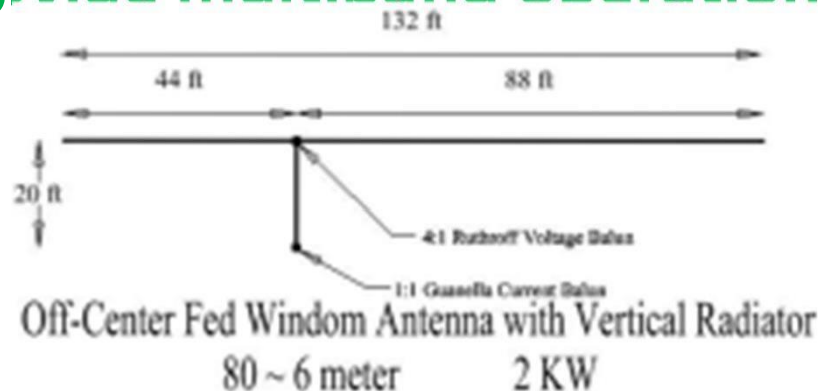

E9C06 (B)

What is the effect of a terminating resistor on a rhombic antenna? **It changes the radiation pattern from bidirectional to unidirectional**

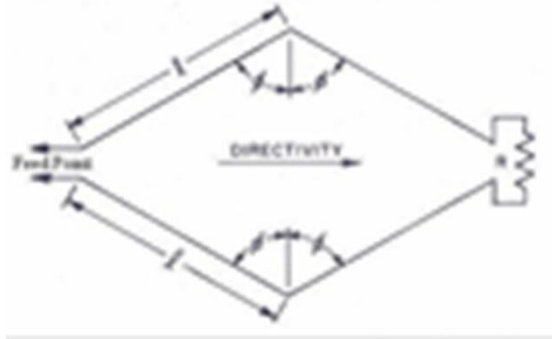

E9C07 (A)

What is the approximate feed point impedance at the center of a two-wire folded dipole antenna? **300 ohms**

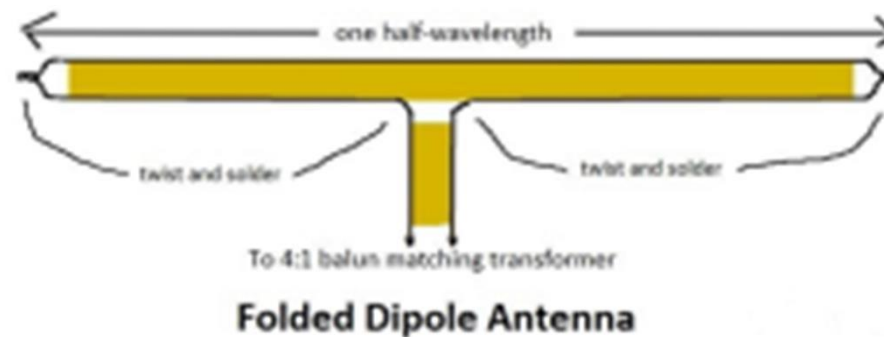

E9C08 (C)

What is a folded dipole antenna? **A dipole consisting of one wavelength of wire forming a very thin loop**

E9C09 (A)

What is a G5RV antenna? **A multi-band dipole antenna fed with coax and a balun through a selected length of open wire transmission line**

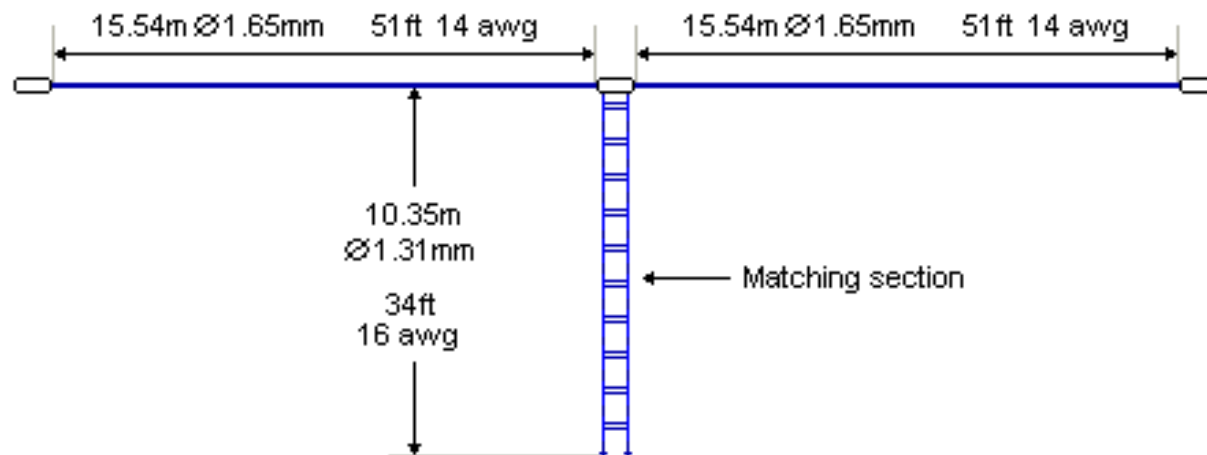

E9C10 (B)

Which of the following describes a Zepp antenna? **An end fed dipole antenna**

An

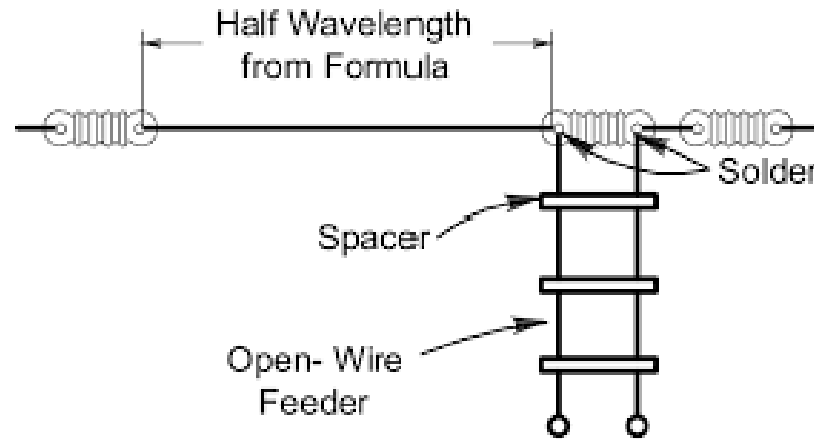

E9C11 (D)

How is the far-field elevation pattern of a vertically polarized antenna affected by being mounted over seawater versus rocky ground? **The low-angle radiation increases**

Low angle radiation is better for long distance communication.

E9C12 (C)

Which of the following describes an extended double Zepp antenna? **A center fed 1.25 wavelength antenna (two 5/8 wave elements in phase)**

E9C13 (C)

What is the main effect of placing a vertical antenna over an imperfect ground? **It reduces low-angle radiation**

E9C14 (B)

How does the performance of a horizontally polarized antenna mounted on the side of a hill compare with the same antenna mounted on flat ground? **The main lobe takeoff angle decreases in the downhill direction**

E9C15 (B)

How does the radiation pattern of a horizontally polarized 3-element beam antenna vary with its height above ground? **The main lobe takeoff angle decreases with increasing height**

Element 9 Sub-Element D

E9D01 (C)

How does the gain of an ideal parabolic dish antenna change when the operating frequency is doubled?

Gain increases by 6 dB



E9D02 (C)

How can linearly polarized Yagi antennas be used to produce circular polarization? **Arrange two Yagis perpendicular to each other with the driven elements at the same point on the boom fed 90 degrees out of phase**

E9D03 (A)

Where should a high Q loading coil be placed to minimize losses in a shortened vertical antenna? **Near the center of the vertical radiator**



E9D04 (C)

Why should an HF mobile antenna loading coil have a high ratio of reactance to resistance? **To minimize losses**

E9D05 (A)

What is a disadvantage of using a multiband trapped antenna? **It might radiate harmonics**

E9D06 (B)

What happens to the bandwidth of an antenna as it is shortened through the use of loading coils? **It is decreased**

E9D07 (D)

What is an advantage of using top loading in a shortened HF vertical antenna? **Improved radiation efficiency**

E9D08 (B)

What happens as the Q of an antenna increases? **The SWR bandwidth decreases gain is reduced**

E9D09 (D)

What is the function of a loading coil used as part of an HF mobile antenna? **To cancel capacitive reactance**

E9D10 (B)

What happens to feed point impedance at the base of a fixed length HF mobile antenna as the frequency of operation is lowered? **The radiation resistance decreases and the capacitive reactance increases**

E9D11 (B)

Which of the following types of conductors would be best for minimizing losses in a station's RF ground system? **A wide flat copper strap**

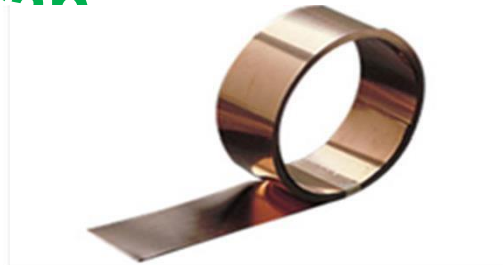

E9D12 (C)

Which of the following would provide the best RF ground for your station? **An electrically short connection to 3 or 4 interconnected ground rods driven into the Earth**

Element 9 Sub-Element E

E9E01 (B)

What system matches a higher impedance transmission line to a lower impedance antenna by connecting the line to the driven element in two places spaced a fraction of a wavelength each side of element center?

The delta matching system

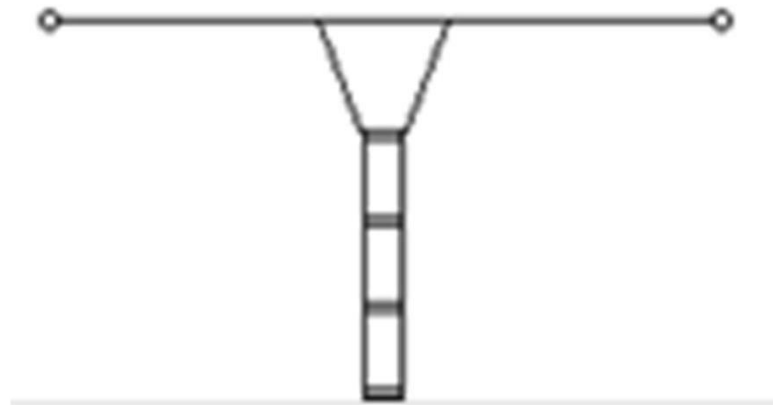

E9E02 (A)

What is the name of an antenna matching system that matches an unbalanced feed line to an antenna by feeding the driven element both at the center of the element and at a fraction of a wavelength to one side of center? **The gamma match**

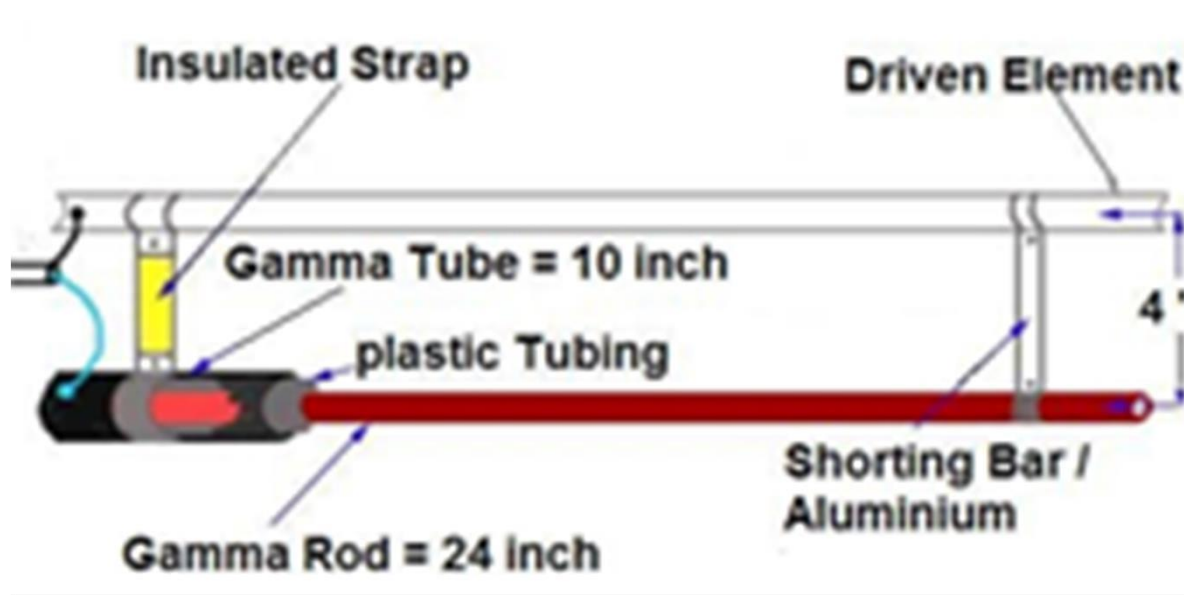

E9E03 (D)

What is the name of the matching system that uses a section of transmission line connected in parallel with the feed line at or near the feed point? **The stub match**

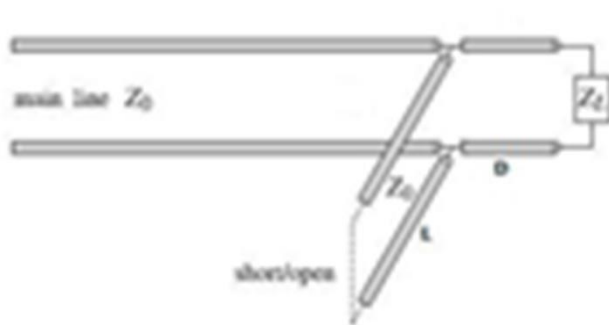

E9E04 (B)

What is the purpose of the series capacitor in a gamma-type antenna matching network? **To cancel the inductive reactance of the matching network**

E9E07 (B)

What term best describes the interactions at the load end of a mismatched transmission line? **Reflection coefficient**

E9E08 (D)

Which of the following measurements is characteristic of a mismatched transmission line? **An SWR greater than 1:1**

E9E09 (C)

Which of these matching systems is an effective method of connecting a 50 ohm coaxial cable feed line to a grounded tower so it can be used as a vertical antenna? **Gamma match**

E9E10 (C)

Which of these choices is an effective way to match an antenna with a 100 ohm feed point impedance to a 50 ohm coaxial cable feed line? **Insert a 1/4-wavelength piece of 75 ohm coaxial cable transmission line in series between the antenna terminals and the 50 ohm feed cable**

E9E11 (B)

What is an effective way of matching a feed line to a VHF or UHF antenna when the impedances of both the antenna and feed line are unknown? **Use the universal stub matching technique**

E9E12 (A)

What is the primary purpose of a phasing line when used with an antenna having multiple driven elements? **It ensures that each driven element operates in concert with the others to create the desired antenna pattern**

E9E13 (C)

What is a use for a Wilkinson divider? **It is used to divide power equally between two 50 ohm loads while maintaining 50 ohm input impedance**

In the field of engineering and circuit design, the Wilkinson Power Divider is a specific class of power divider circuit that can achieve isolation between the output ports while maintaining a matched condition on all ports. The Wilkinson design can also be used as a power combiner because it is made up of passive components and hence reciprocal. First published by Ernest J. Wilkinson in 1960, this circuit finds wide use in RF communication systems utilizing multiple channels since the high degree of isolation between the output ports prevents crosstalk between the individual channels.

Element 9 Sub-Element F

E9F01 (D)

What is the velocity factor of a transmission line? **The velocity of the wave in the transmission line divided by the velocity of light in a vacuum**

E9F02 (C)

Which of the following determines the velocity factor of a transmission line? **Dielectric materials used in the line**

E9F03 (D)

Why is the physical length of a coaxial cable transmission line shorter than its electrical length?

Electrical signals move more slowly in a coaxial cable than in air

E9F04 (B)

What is the typical velocity factor for a coaxial cable with solid polyethylene dielectric? 0.66

E9F05 (C)

What is the approximate physical length of a solid polyethylene dielectric coaxial transmission line that is electrically one-quarter wavelength long at 14.1 MHz? **3.5 meters**

$$\begin{aligned} \frac{1}{4} \text{ wavelength} &= (0.25 (300 \div 14.1))(0.66) \text{ or} \\ & .(25 \times 21.28)(0.66) \text{ or } 5.319 \times 0.66 \text{ or } 3.51 \text{ meters} \end{aligned}$$

E9F06 (C)

What is the approximate physical length of an air-insulated, parallel conductor transmission line that is electrically one-half wavelength long at 14.10 MHz? **10 meters**

$$\begin{aligned} \frac{1}{2} \text{ wavelength} &= 0.5 (300 \div 14.1) \text{ or } 0.5 \times 21.28 \text{ or} \\ & 10.6 \text{ meters} \end{aligned}$$

E9F07 (A)

How does ladder line compare to small-diameter coaxial cable such as RG-58 at 50 MHz? **Lower loss**

E9F08 (A)

What is the term for the ratio of the actual speed at which a signal travels through a transmission line to the speed of light in a vacuum? **Velocity factor**

E9F09 (B)

What is the approximate physical length of a solid polyethylene dielectric coaxial transmission line that is electrically one-quarter wavelength long at 7.2 MHz?

6.9 meters

$$\frac{1}{4} \text{ wavelength} = (300 \div 7.2)(.25)(0.66) \text{ or } (41.6)(.25)(.66) \text{ or } (10.42)(0.66) \text{ or } 6.87 \text{ meters}$$

E9F10 (C)

What impedance does a $1/8$ wavelength transmission line present to a generator when the line is shorted at the far end? **An inductive reactance**

1/8-wavelength transmission line presents an inductive reactance to a generator when the line is shorted at the far end.

E9F11 (C)

What impedance does a $1/8$ wavelength transmission line present to a generator when the line is open at the far end? **A capacitive reactance**

A 1/8-wavelength transmission line presents a capacitive reactance to a generator when the line is open at the far end.

E9F12 (D)

What impedance does a $1/4$ wavelength transmission line present to a generator when the line is open at the far end? **Very low impedance**

A $1/4$ -wavelength transmission line presents very low impedance to a generator when the line is open at the far end.

E9F13 (A)

What impedance does a $1/4$ wavelength transmission line present to a generator when the line is shorted at the far end? **Very high impedance**

A $1/4$ -wavelength transmission line presents very high impedance to a generator when the line is shorted at the far end.

E9F14 (B)

What impedance does a $1/2$ wavelength transmission line present to a generator when the line is shorted at the far end? **Very low impedance**

There is minimum voltage and maximum current at either end of the line, which corresponds to the condition of a short circuit.

E9F15 (A)

What impedance does a $1/2$ wavelength transmission line present to a generator when the line is open at the far end? **Very high impedance**

There is maximum voltage and minimum current at the end of the line, which corresponds to the condition of an open circuit.

E9F16 (D)

Which of the following is a significant difference between foam dielectric coaxial cable and solid dielectric cable, assuming all other parameters are the same?

- A. Foam dielectric has lower safe operating voltage limits**
- B. Foam dielectric has lower loss per unit of length**
- C. Foam dielectric has higher velocity factor**
- D. All of these choices are correct**

Element 9 Sub Element G

E9G01 (A)

Which of the following can be calculated using a Smith chart? **Impedance along transmission lines**

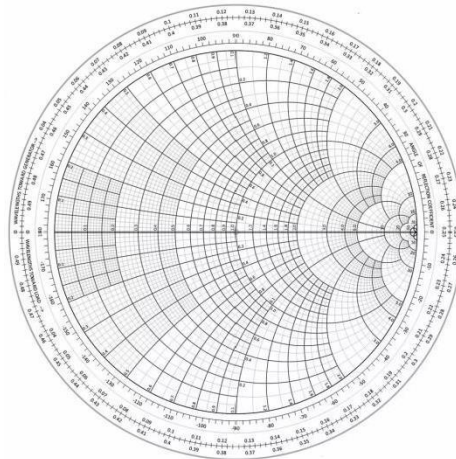

E9G02 (B)

What type of coordinate system is used in a Smith chart? **Resistance circles and reactance arcs**

E9G03 (C)

Which of the following is often determined using a Smith chart? **Impedance and SWR values in transmission lines**

E9G04 (C)

What are the two families of circles and arcs that make up a Smith chart? **Resistance and reactance**

E9G05 (A)

What type of chart is shown in Figure E9-3? **Smith chart**

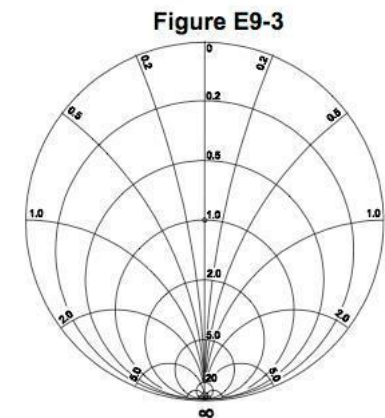

E9G06 (B)

On the Smith chart shown in Figure E9-3, what is the name for the large outer circle on which the reactance arcs terminate? **Reactance axis**

E9G07 (D)

On the Smith chart shown in Figure E9-3, what is the only straight line shown? **The resistance axis**

E9G08 (C)

What is the process of normalization with regard to a Smith chart? **Reassigning impedance values with regard to the prime center**

E9G09 (A)

What third family of circles is often added to a Smith chart during the process of solving problems?

Standing wave ratio circles

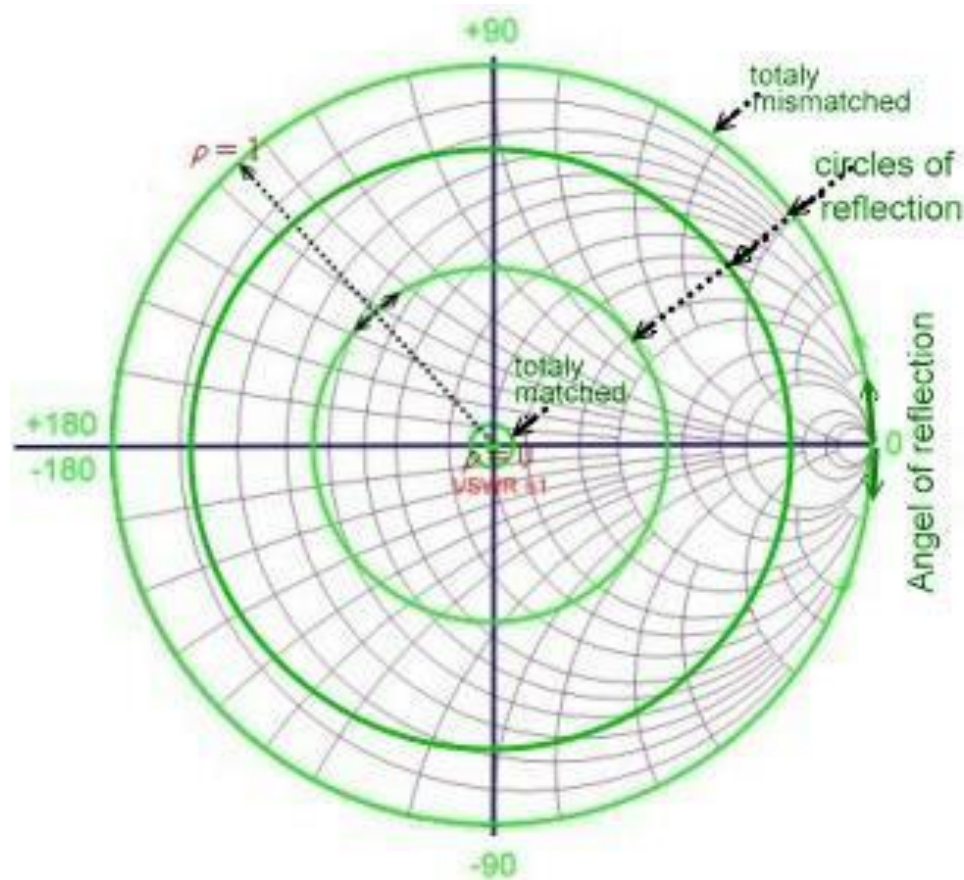

E9G10 (D)

What do the arcs on a Smith chart represent? **Points with constant reactance**

E9G11 (B)

How are the wavelength scales on a Smith chart calibrated? **In fractions of transmission line electrical wavelength**

Element 9 Sub Element H

E9H01 (D)

When constructing a Beverage antenna, which of the following factors should be included in the design to achieve good performance at the desired frequency? **It should be one or more wavelengths long**

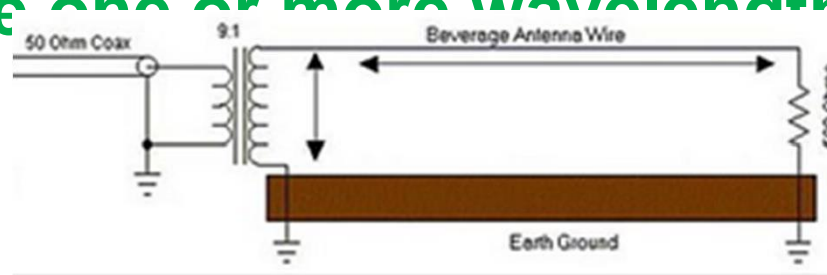

E9H02 (A)

Which is generally true for low band (160 meter and 80 meter) receiving antennas? **Atmospheric noise is so high that gain over a dipole is not important**

E9H03 DELETED February 1, 2016

E9H04 (B)

What is an advantage of using a shielded loop antenna for direction finding? **It is electro statically balanced against ground, giving better nulls**

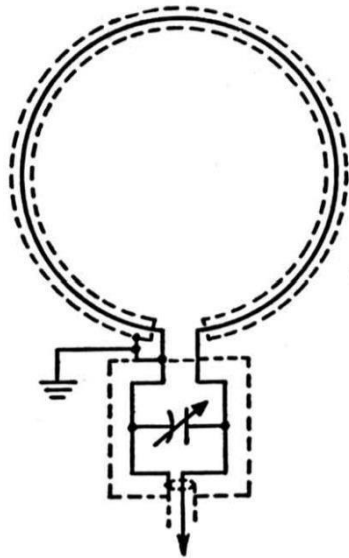

E9H05 (A)

What is the main drawback of a wire-loop antenna for direction finding? **It has a bidirectional pattern**

E9H06 (C)

What is the triangulation method direction finding? **Antenna headings from several different receiving locations are used to locate the signal source**

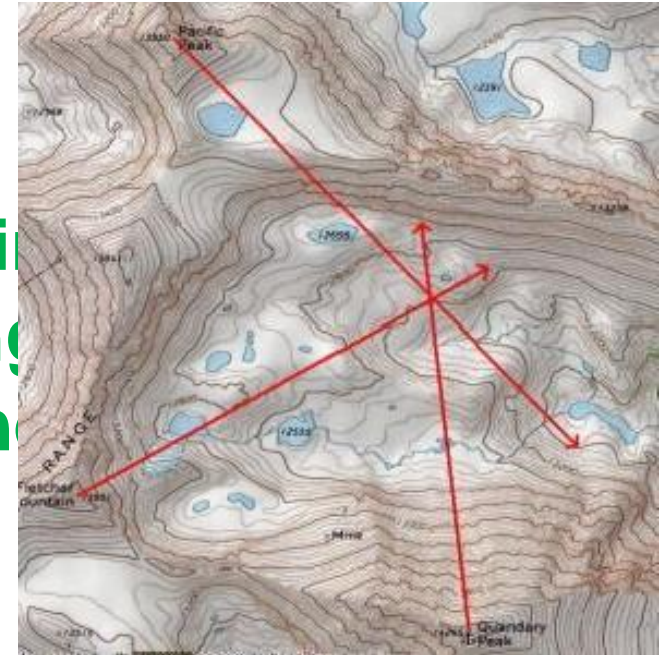

9H07 (D)

Why is it advisable to use an RF attenuator on a receiver being used for direction finding? **It prevents receiver overload which could make it difficult to determine peaks or nulls**



E9H08 (A)

What is the function of a sense antenna? **It modifies the pattern of a DF antenna array to provide a null in one direction**

The sense antenna picks up signals with equal strength from all directions. An ADF (Automatic Direction Finding) system uses two antennas-a loop antenna and a sense antenna. The loop antenna is highly directional; the strength of the signal it picks up changes with the direction between the antenna and the station. But the signal strength is the same if the station is in front of the antenna or behind it. The signals picked up by both the loop antenna and the sense antenna are fed into the same equipment, and as the two signals mix, they form a pattern that allows the ADF system to measure the exact direction between the loop antenna and the station being received. Using the sense antenna eliminates the problem of 180° ambiguity. It allows the system to distinguish whether the station is in front of the antenna or behind it.

E9H09 (C)

Which of the following describes the construction of a receiving loop antenna? **One or more turns of wire wound in the shape of a large open coil**

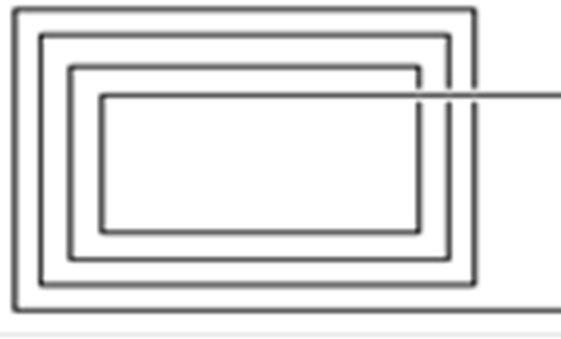

E9H10 (D)

How can the output voltage of a multiple turn receiving loop antenna be increased? **By increasing either the number of wire turns in the loop or the area of the loop structure or both**

E9H11 (B)

What characteristic of a cardioid pattern antenna is useful for direction finding? **A very sharp single null**

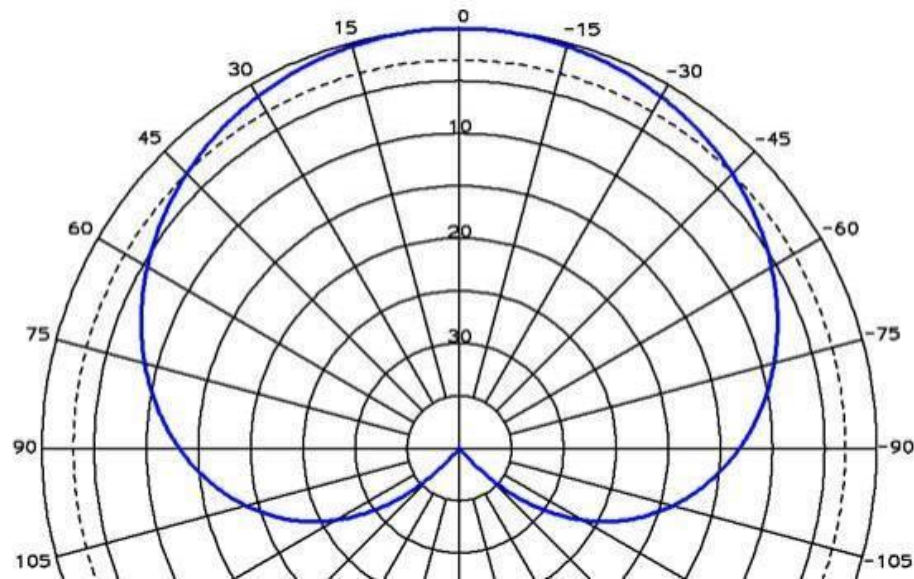

ELEMENT E0

Safety

[8 Exam Questions - 8 Groups]

Element 0 Sub-Element A

E0A01 (B)

What is the primary function of an external earth connection or ground rod? **Lightning protection**



E0A02 (B)

When evaluating RF exposure levels from your station at a neighbor's home, what must you do? **Make sure signals from your station are less than the uncontrolled MPE limits**

When using a gain antenna you must be sure it cannot be pointed directly at the neighbor's home

E0A03 (C)

Which of the following would be a practical way to estimate whether the RF fields produced by an amateur radio station are within permissible MPE limits? **Use an antenna modeling program to calculate field strength at accessible locations**

E0A04 (C)

When evaluating a site with multiple transmitters operating at the same time, the operators and licensees of which transmitters are responsible for mitigating over-exposure situations? **Each transmitter that produces 5 percent or more of its MPE limit at accessible locations**

If your 100 watt repeater with a 3db gain antenna is collocated with a 2,000 watt transmitter both licenses are responsible. 5% of 2,000 watts is $0.05 \times 2,000$ or 200 watts which is your transmitter output with a 3dB gain antenna.

E0A05 (B)

What is one of the potential hazards of using microwaves in the amateur radio bands? **The high gain antennas commonly used can result in high exposure levels**

E0A06 (D)

Why are there separate electric (E) and magnetic (H) field MPE limits?

- A. The body reacts to electromagnetic radiation from both the E and H fields**
- B. Ground reflections and scattering make the field impedance vary with location**
- C. E field and H field radiation intensity peaks can occur at different locations**
- D. All of these choices are correct**

E0A07 (B)

How may dangerous levels of carbon monoxide from an emergency generator be detected? **Only with a carbon monoxide detector.**

E0A08 (C)

What does SAR measure? **The rate at which RF energy is absorbed by the body**

SAR (Specific Absorption Rate) is a measure of the rate at which energy is absorbed by the human body when exposed to a radio frequency (RF) electromagnetic field. The SAR varies with frequency.

E0A09 (C)

Which insulating material commonly used as a thermal conductor for some types of electronic devices is extremely toxic if broken or crushed and the particles are accidentally inhaled? **Beryllium Oxide**



E0A10 (A)

What toxic material may be present in some electronic components such as high voltage capacitors and transformers? **Polychlorinated Biphenyls**



E0A11 (C)

Which of the following injuries can result from using high-power UHF or microwave transmitters? **Localized heating of the body from RF exposure in excess of the MPE limits**

You did it!



Congratulations!!!

You have completed the
Extra License Class